

FOCAL/RENAULT

INSTALLATION OF LIVE / PREMIUM KITS FOR RENAULT
Espace V – February 2016



RECOMMENDATIONS BEFORE INSTALLATION

- Reset all car radio audio settings:
 - Ambience = Natural
 - Bass / Midrange / Treble settings = 0
 - Loudness = OFF
 - Fader and Balance = Centred
- The speaker drivers require a break-in period (approximately 20 hours) before they reach optimal sound quality.
After this break-in period, you can fine-tune the audio settings as you please.

I. ASSEMBLING THE FRONT SPEAKER DRIVERS

1. Equipment required for assembling the woofer

Connector

Crossover

Spacer



I. ASSEMBLING THE FRONT SPEAKER DRIVERS

2. Connections

Note:

the crossover (with the black shielding) can be mounted any way around.



Speaker driver

Crossover



Fasten the crossover in place using a cable tie.

Note:

the cable tie mustn't come into contact with the spider (yellow part) when the speaker driver is in motion.

II. INSTALLING THE FRONT SPEAKER DRIVERS

The picture below shows the location of the screws to remove.



1. Unclip the door panels using prying tools.



II. INSTALLING THE FRONT SPEAKER DRIVERS

2. Remove the original speaker driver



3. Rivet and connect the speaker driver



III. ASSEMBLING THE TWEETERS

1. Equipment required for assembling the tweeter.

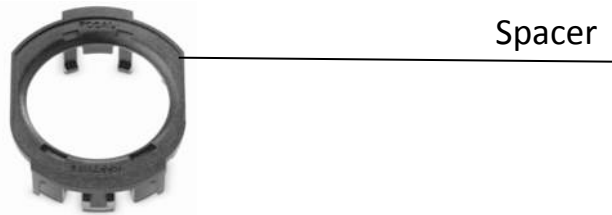

Spacer

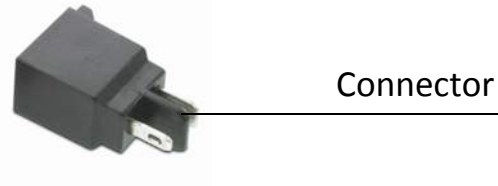

Connector

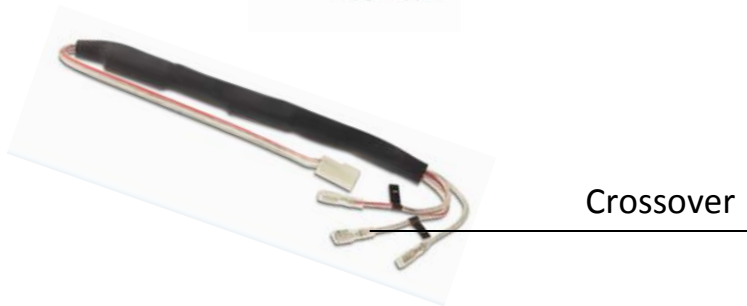

Crossover

2. Remove the grille by simply unclipping it.



III. ASSEMBLING THE TWEETERS

3. Slot the tweeter into the spacer making sure it's the right way up.

Note:
slot the wires into the same side the 2 tabs are fixed to.



4. Connect at position 2

Note:
position 1 is not used in this set-up.

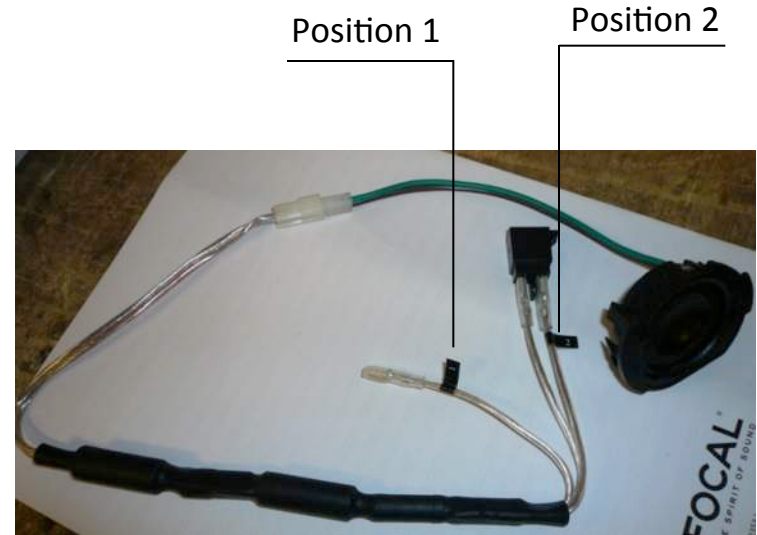

IV. INSTALLING THE TWEETERS

1. Remove the tweeter grille



2. Remove the tweeter



IV. INSTALLING THE TWEETERS

3. Connect the Focal tweeter and clip it into its housing

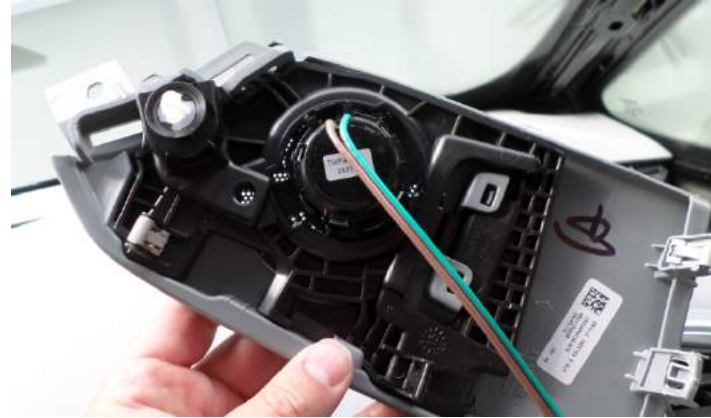

4. Connect the crossover as shown on the picture



5. Stick the logo included with the kit onto the grille



V. ASSEMBLING THE REAR SPEAKER DRIVERS

1. Equipment required for assembling the woofer

Connector

Crossover

Spacer



V. ASSEMBLING THE REAR SPEAKER DRIVERS

2. Connections

Note:

the crossover (with the black shielding) can be mounted any way around.



Speaker driver

Crossover



Fasten the crossover in place using a cable tie.

Note:

the cable tie mustn't come into contact with the spider (yellow part) when the speaker driver is in motion.

VI. INSTALLING THE REAR SPEAKER DRIVERS

The picture below shows the location of the screws to remove.



1. Unclip the door panels using prying tools.



VI. INSTALLING THE REAR SPEAKER DRIVERS

2. Remove the original speaker driver



3. Rivet and connect the Focal speaker driver



VII. ASSEMBLING THE REAR TWEETERS

1. Equipment required for assembling the tweeter.

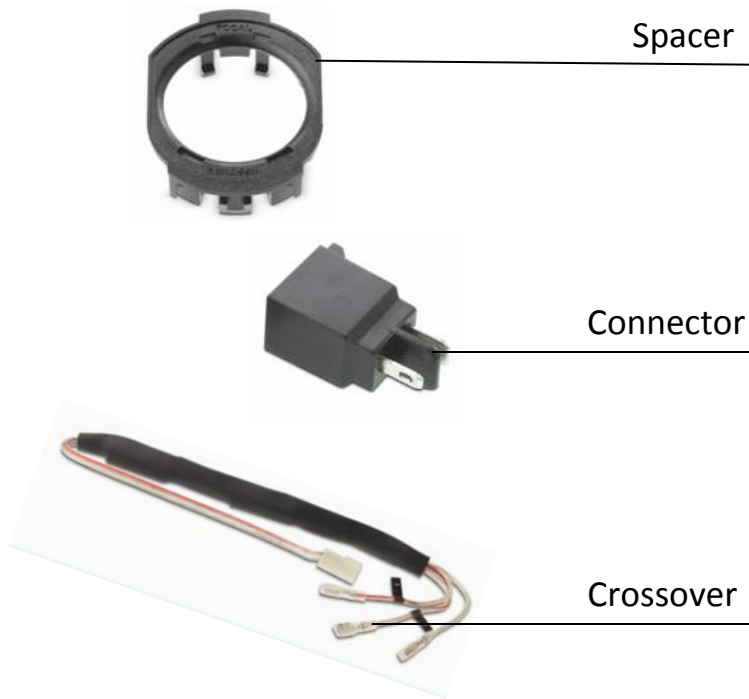

2. Remove the grille by simply unclipping it.



VI. ASSEMBLING THE REAR TWEETERS

3. Slot the tweeter into the spacer making sure it's the right way up.

Note:
slot the wires into the same side the 2 tabs are fixed to.



4. Connect at position 2

Note:
position 1 is not used in this set-up.

Do not connect for the moment

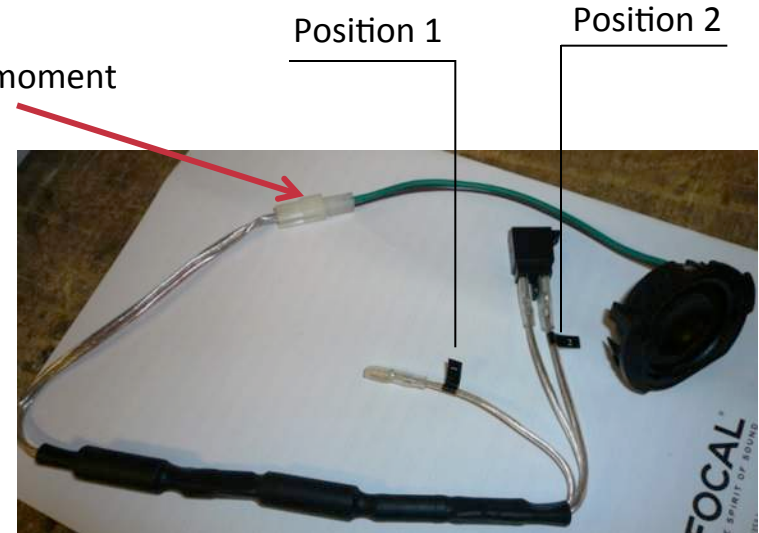

VIII. INSTALLING THE REAR TWEETERS

1. Connect and fix the acoustic crossover as shown below

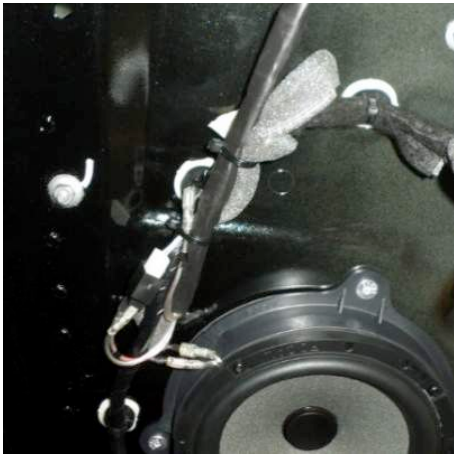

2. Replace the original tweeter with the Focal tweeter



VIII. INSTALLING THE REAR TWEETERS

3. Connect the tweeter to the acoustic crossover when repositioning the door panel

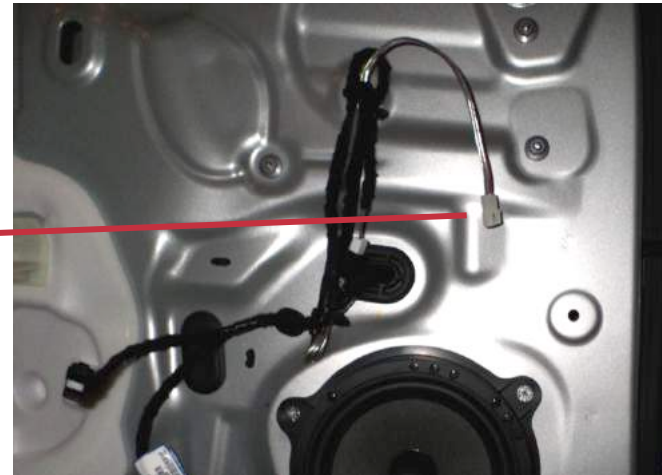

IX. PREPARING THE SUBWOOFER

Equipment required for installing the subwoofer:

Ground cable

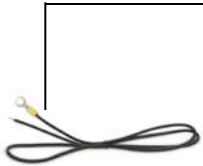

Power cable



Crimp sleeve



Power connector



Subwoofer cable with remote control



Adapter



Ibus 2.1



Extension cable



Head unit – subwoofer interconnect cable



Hook-and-loop fasteners (e.g. Velcro)



Connectors

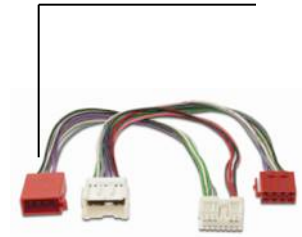

IX. PREPARING THE SUBWOOFER

1. Glue the two strips of hook-and-loop fasteners

Note:

be careful not to cover up the serial number



2. Connect the extension cable to the head unit - subwoofer interconnect cable.

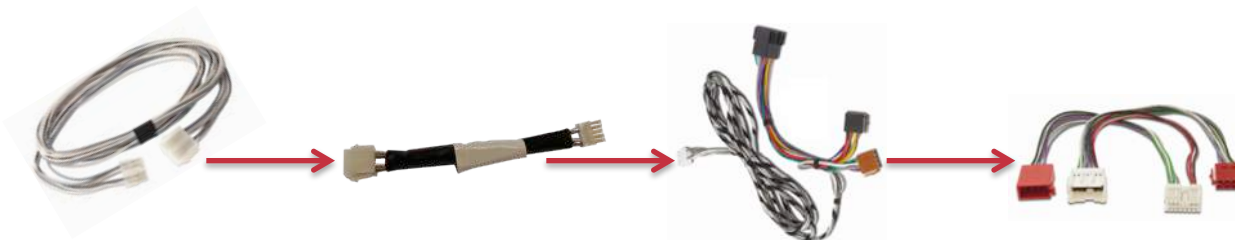

X. POSITIONING AND ADJUSTING THE SUBWOOFER

7-SEATER VEHICLE

5-SEATER VEHICLE

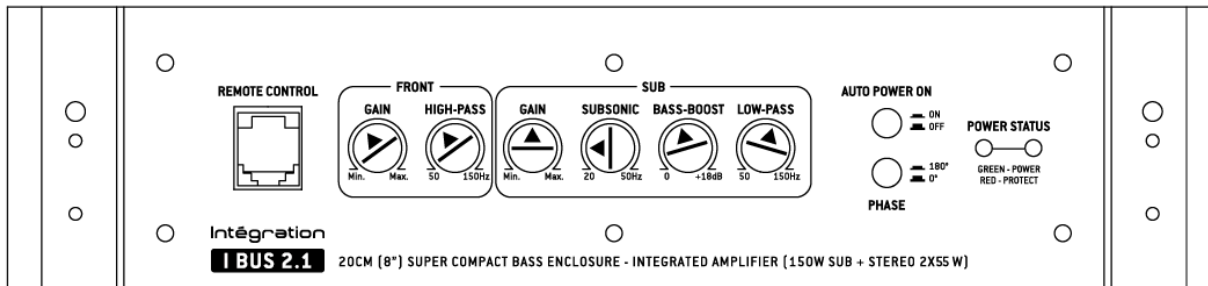

Auto Power = ON

Phase = 0° OU 180°

Phase: 0 or 180, this depends on many parameters, so it is advisable to try both positions without altering any other settings, and then to choose the one which sounds best.

XI. INSTALLING THE SUBWOOFER

1. Remove the left side panel to connect power

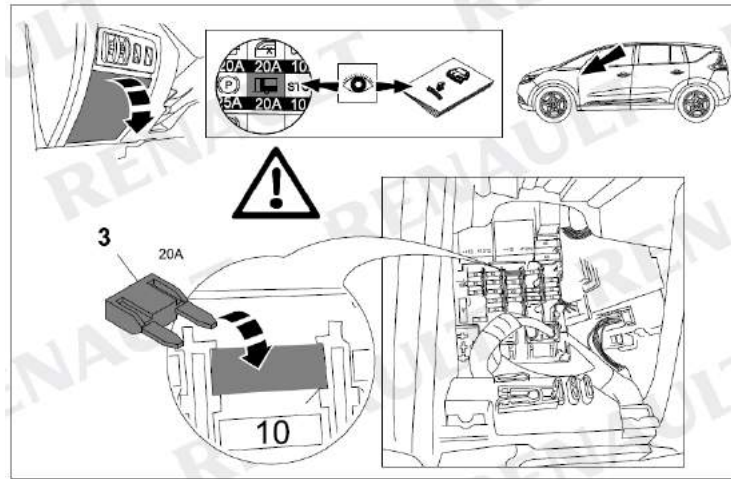
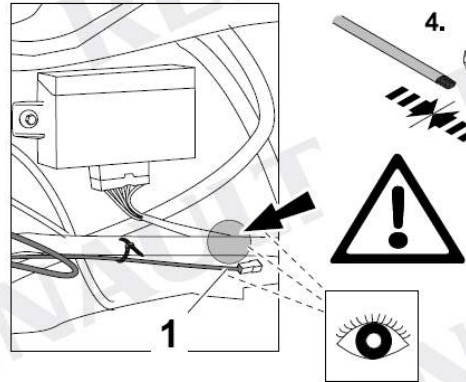
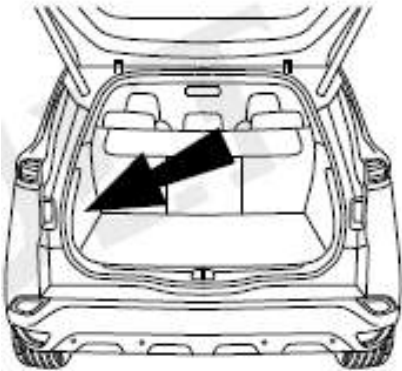

XI. INSTALLING THE SUBWOOFER

2. Run the power connector to the subwoofer to the glove compartment, on the right side of the vehicle



XI. INSTALLING THE SUBWOOFER

3. Remove the entire glove compartment and put it aside.

Note:

be careful not to cover up the serial number.



Note:

Unclip the cap to free the counter spring

XI. INSTALLING THE SUBWOOFER

4. Cut the top of the glove compartment to access to the head unit connection (About 95mm x 95mm)



Note :
*Be careful not to cut too deeply
(the head unit connection is on the top
of the glove compartment)*

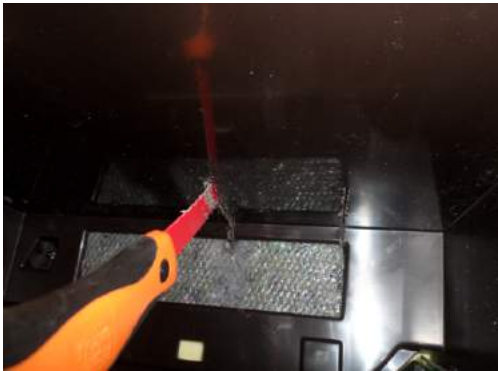

XI. INSTALLING THE SUBWOOFER

5. Connect the subwoofer power connector with the adapter

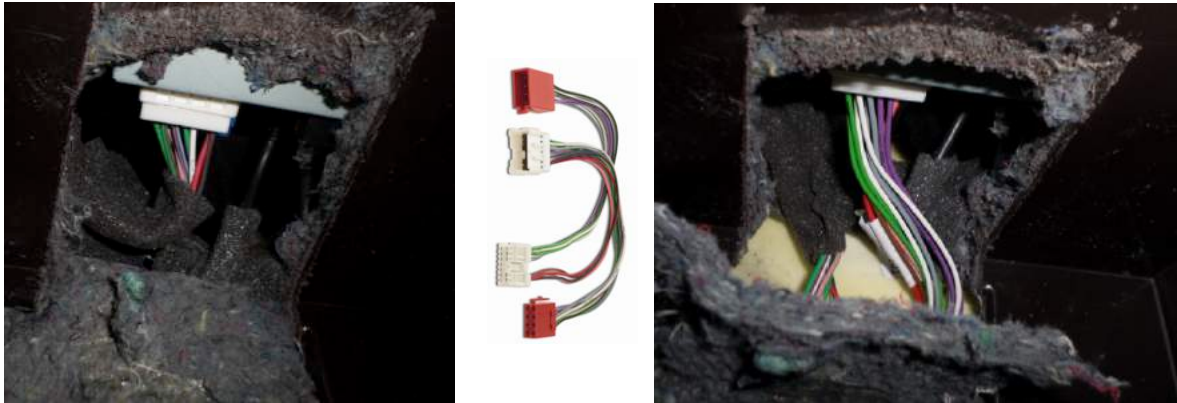

6. Install the remote control



XI. INSTALLING THE SUBWOOFER

7. Use the hook-and-loop fasteners left (not used to fix the subwoofer) to close the hole of the glove compartment

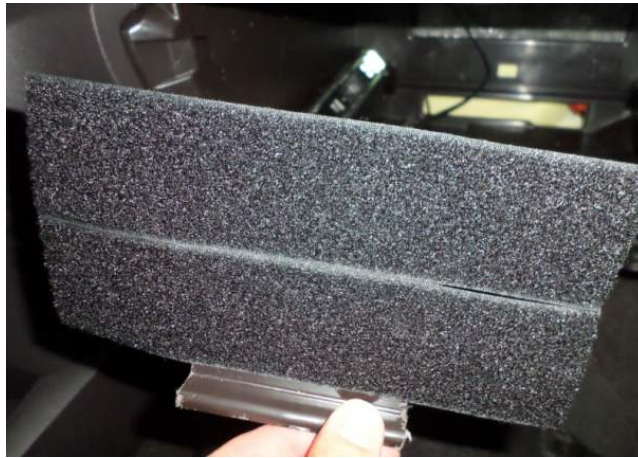



FOCAL® is trademark of FOCAL-JMLAB®

