

FOCAL/RENAULT

INSTALLATION OF LIVE / PREMIUM KITS FOR RENAULT
Duster – March 2017



RECOMMENDATIONS BEFORE INSTALLATION

- Reset all car radio audio settings:
 - Ambience = Natural
 - Bass / Midrange / Treble settings = 0
 - Loudness = OFF
 - Fader and Balance = Centred
- The speaker drivers require a break-in period (approximately 20 hours) before they reach optimal sound quality.
After this break-in period, you can fine-tune the audio settings as you please.

I. UNBOXING AND LOCATION OF PARTS

IFRA165-4.1

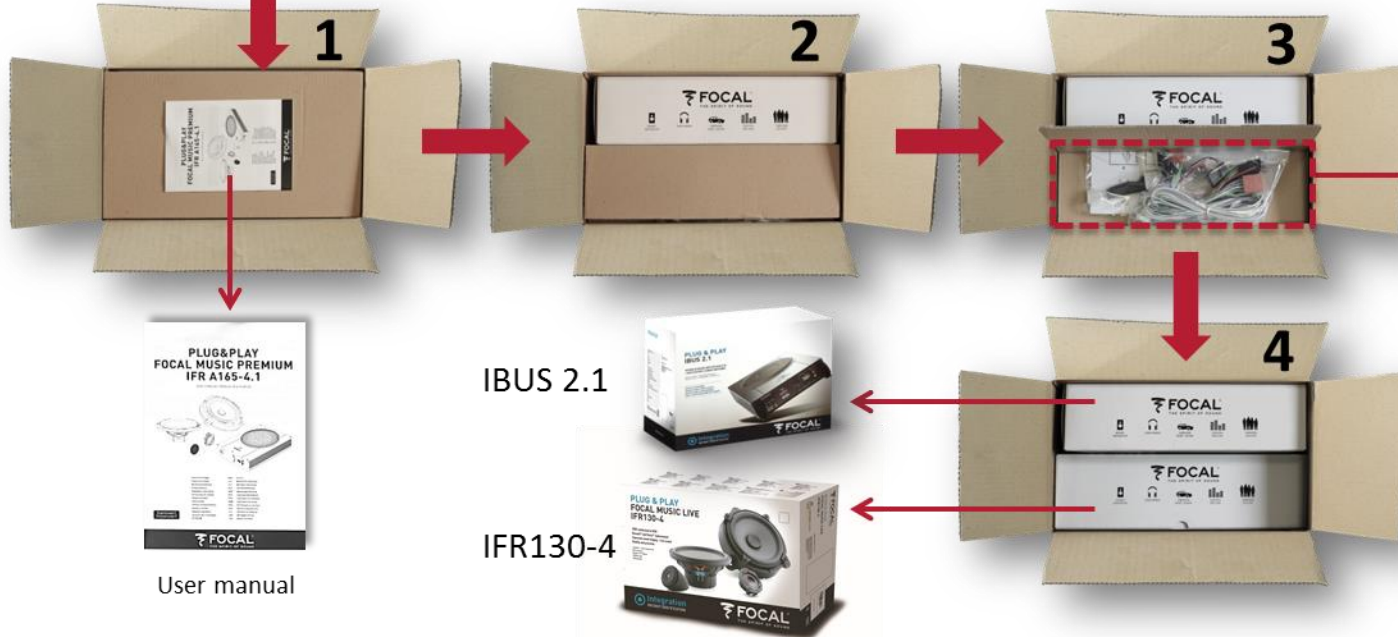
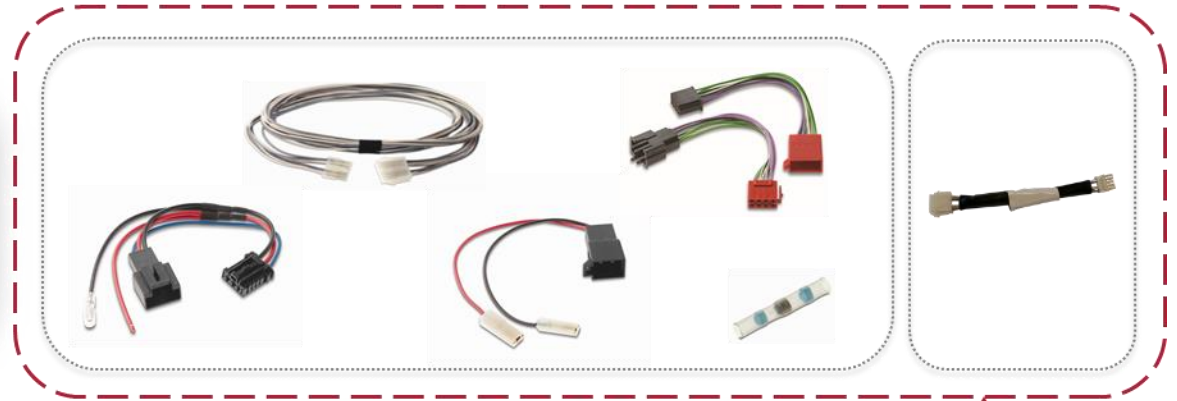

I. UNBOXING AND LOCATION OF PARTS

Ibus 2.1

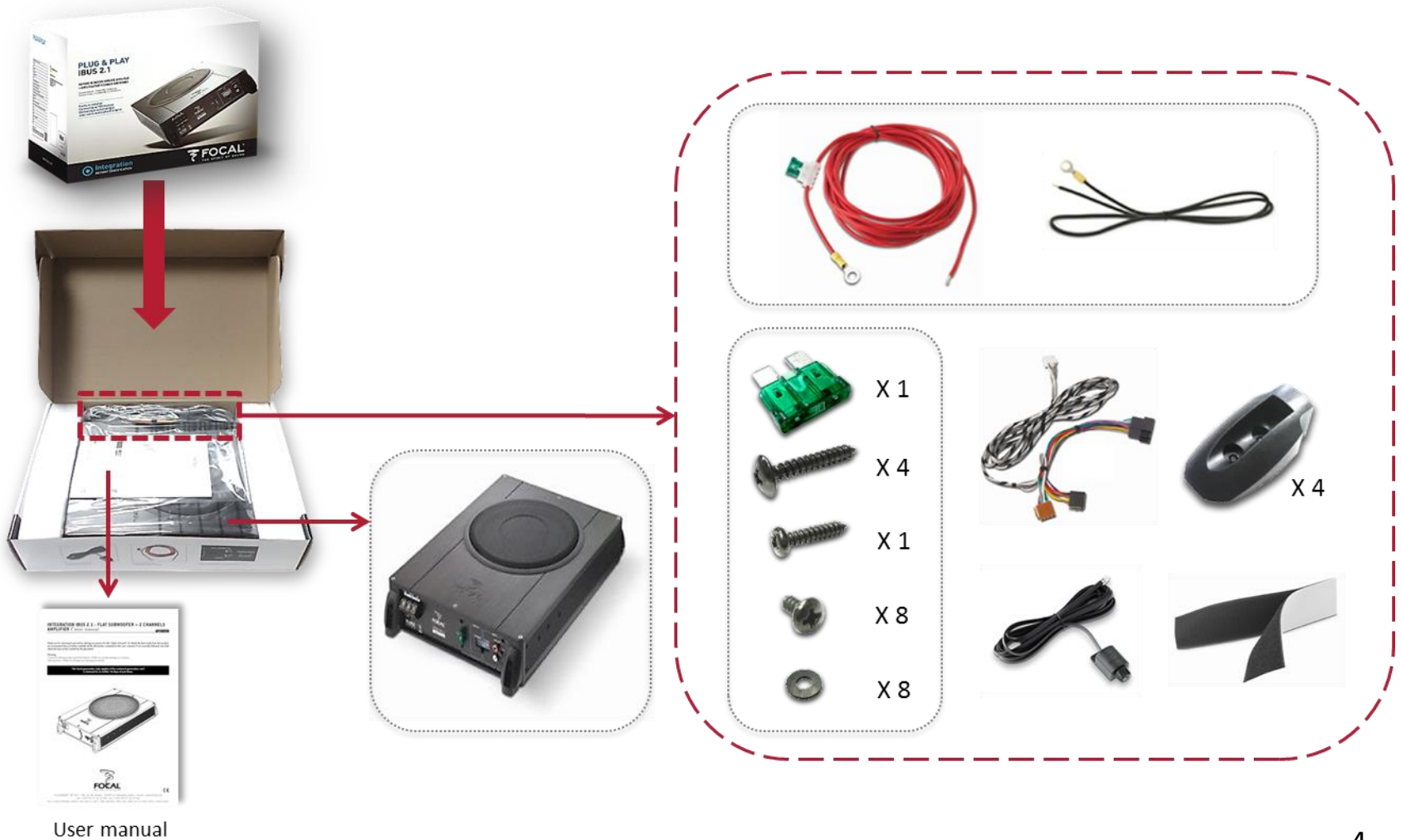

I. UNBOXING AND LOCATION OF PARTS

IFRA130-4

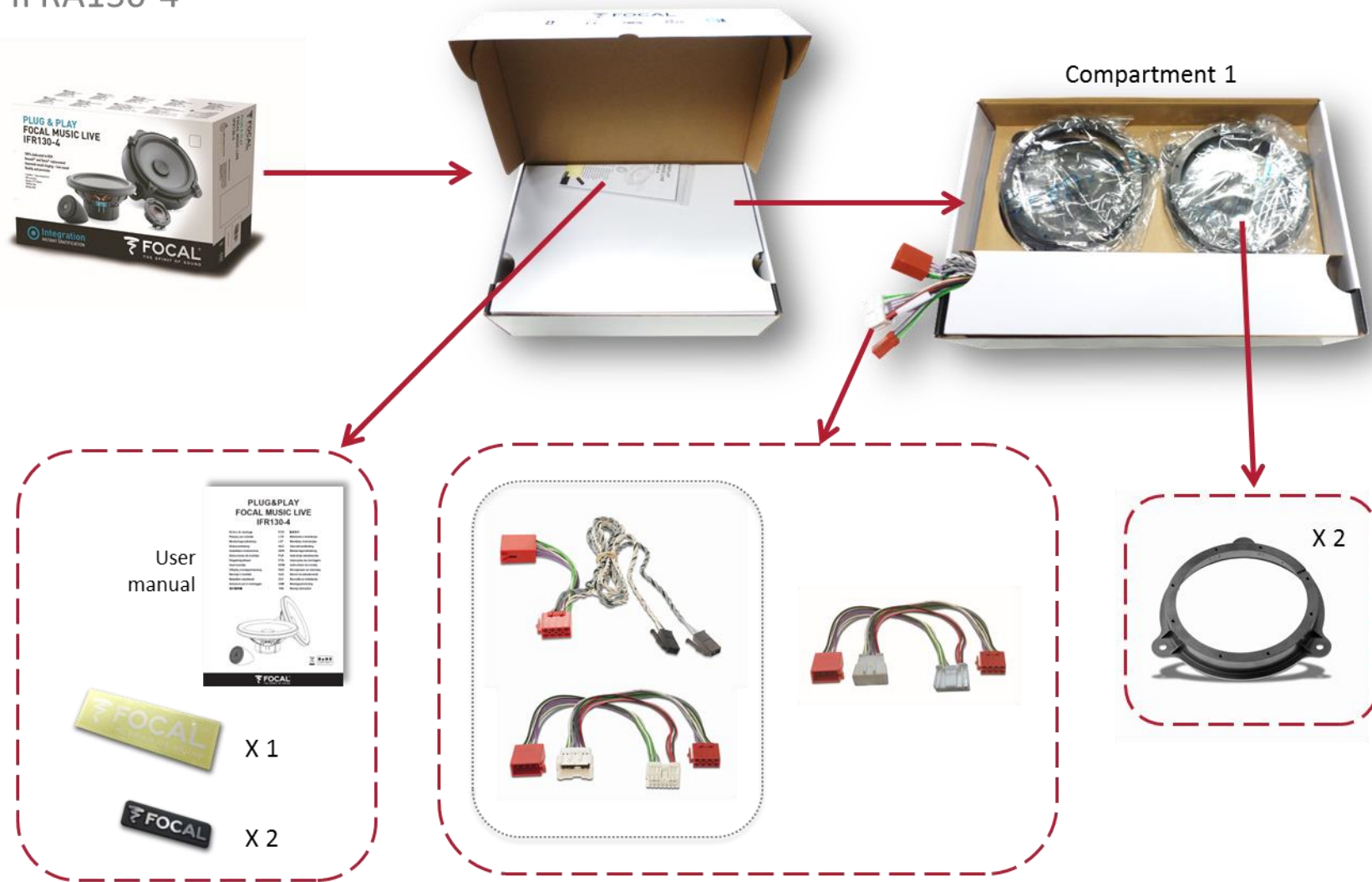

I. UNBOXING AND LOCATION OF PARTS

IFRA130-4

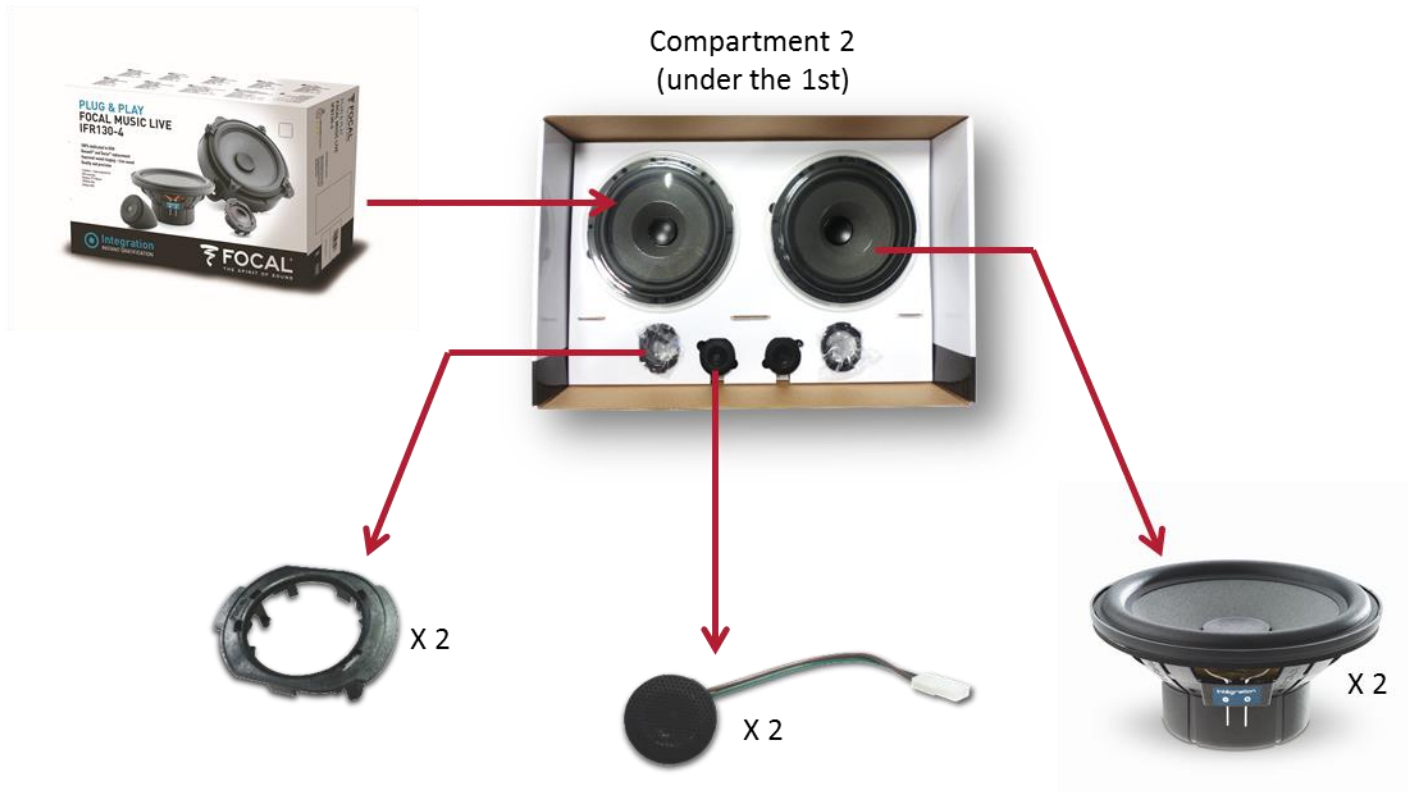

I. UNBOXING AND LOCATION OF PARTS

IFRA130-4

Under « Compartment 2 »



II. ASSEMBLING THE FRONT SPEAKER DRIVERS

1. Equipment required for assembling the woofer.

Crossover



Connector



2. Connections

Note:

the crossover (with the black shielding) can be mounted any way around.



Speaker driver and removable clips



Crossover

III. INSTALLING THE FRONT SPEAKER DRIVERS

1. Remove the original grille and install the new speaker driver



IV. ASSEMBLING THE TWEETERS

1. Equipment required for assembling the tweeter.

Connector



Support

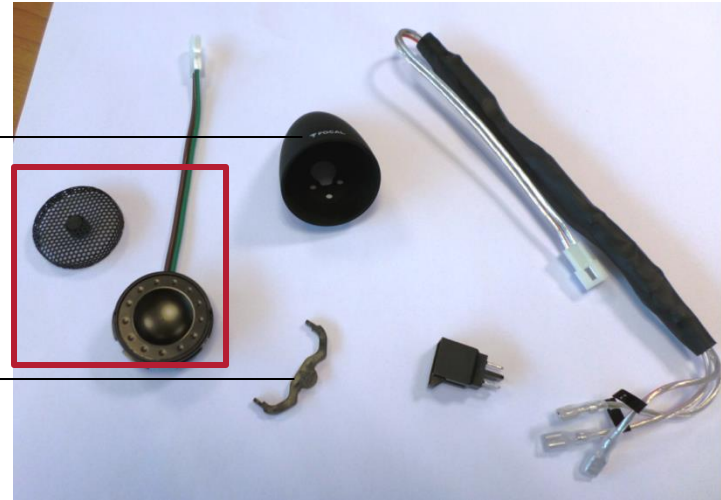

Installation key

Crossover



IV. ASSEMBLING THE TWEETERS

3. Connect at position 1

Note:

Position 2 is not used in this set-up.

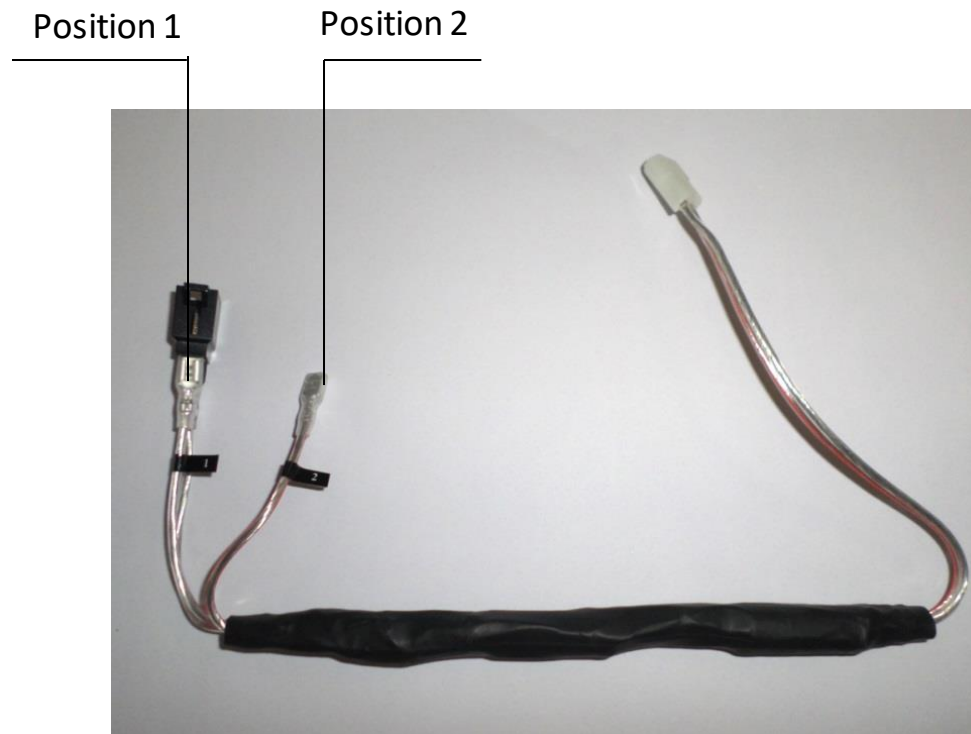

V. CONNECTING THE TWEETERS

1. Wiring required for the tweeter connection



Note:

Be careful to apply the correct fitting orientation (right/left) during the wiring installation in the vehicle.

VI. INSTALLING THE TWEETERS

1. Remove the trim



2. Glue the template (see pages 14 & 15) on the basis of the trim and **mark the holes locations for the screws**

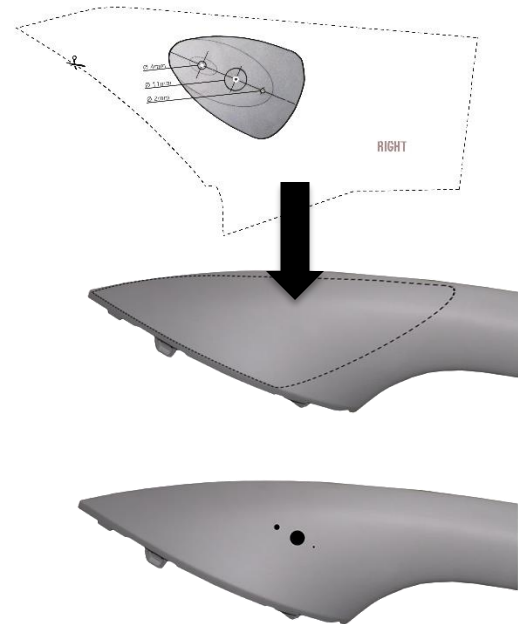

VI. INSTALLING THE TWEETERS

Template to cut out for the **left tweeter**:

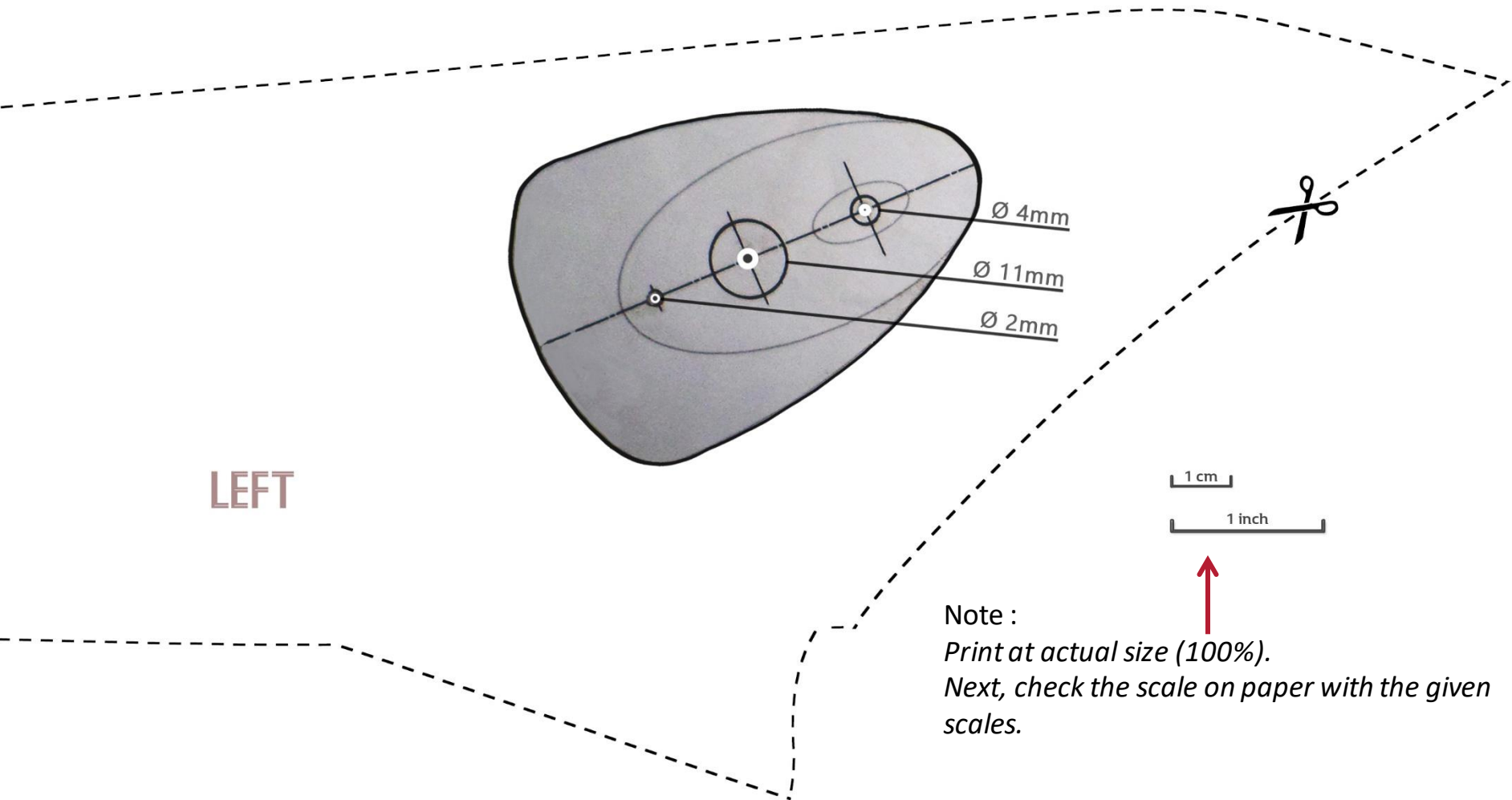

VI. INSTALLING THE TWEETERS

Template to cut out for the **right tweeter**:

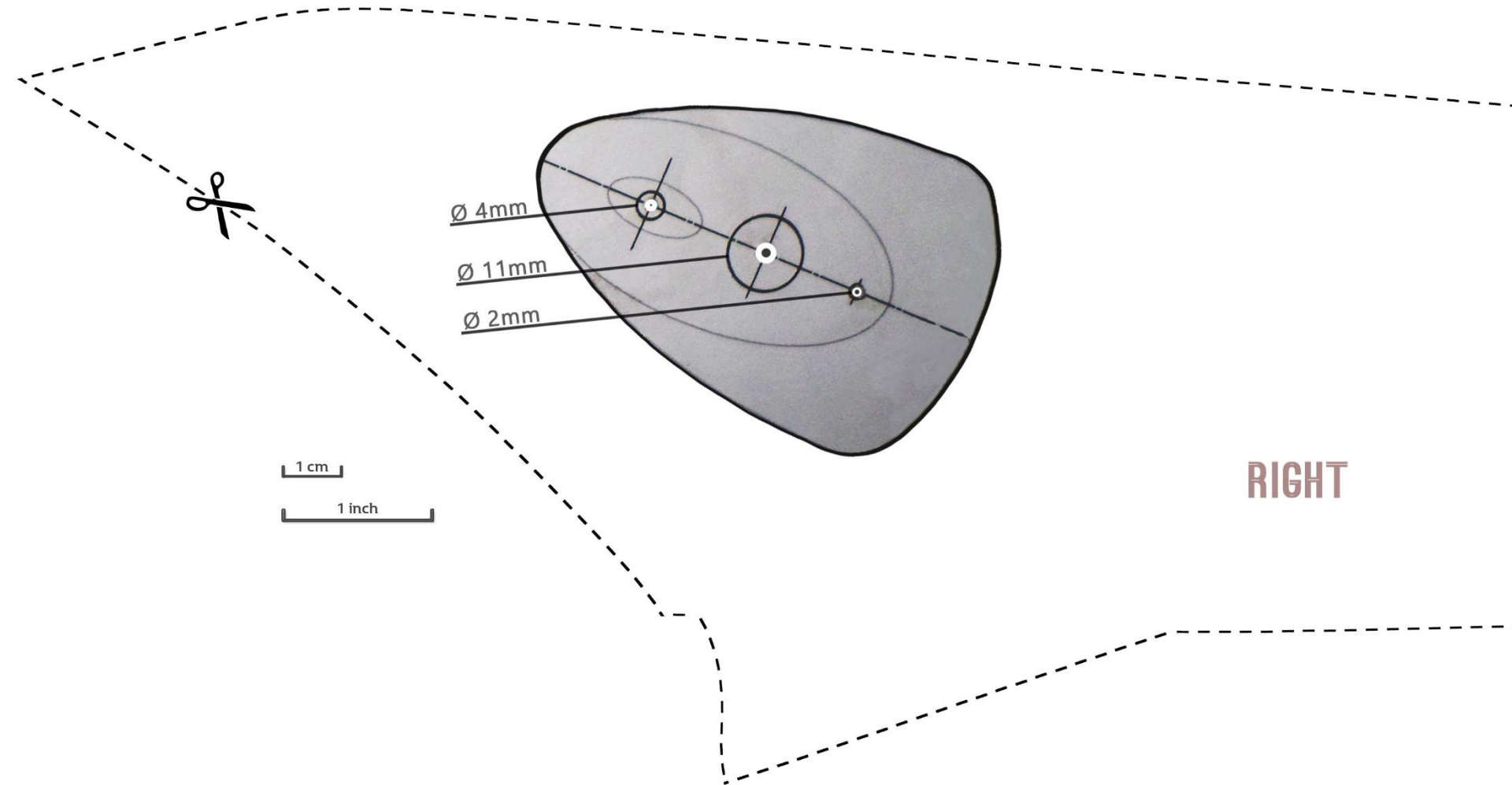

VI. INSTALLING THE TWEETERS

3. Drill the trim and fix the support



VI. INSTALLING THE TWEETERS

4. Place the tweeter, use the key to fix it with a quarter turn counterclockwise and push the grille back

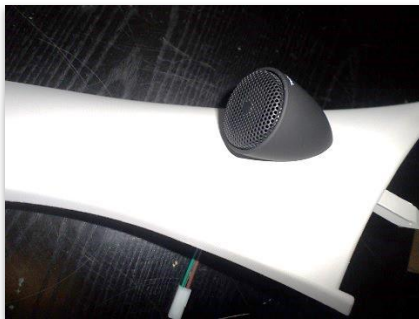
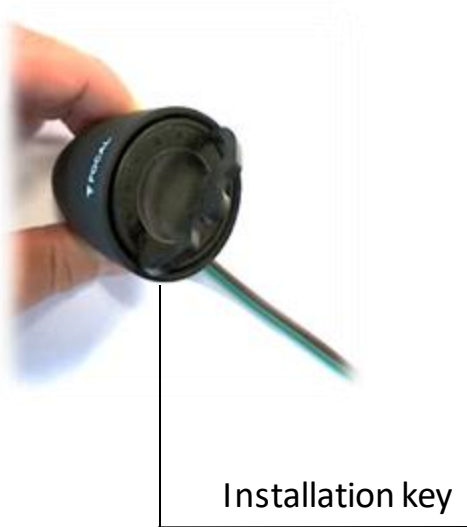
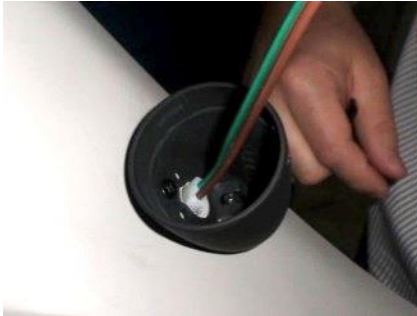

5. Push the trim back



VII. INSTALLING THE TWEETER CONNECTOR

Installing the tweeter connector

White wire on the left & grey wire on the right

A version:

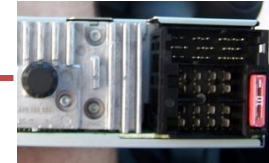
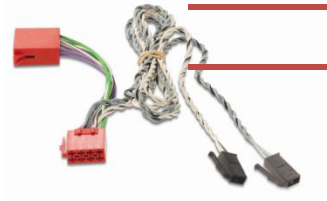

B version: Install the following connector

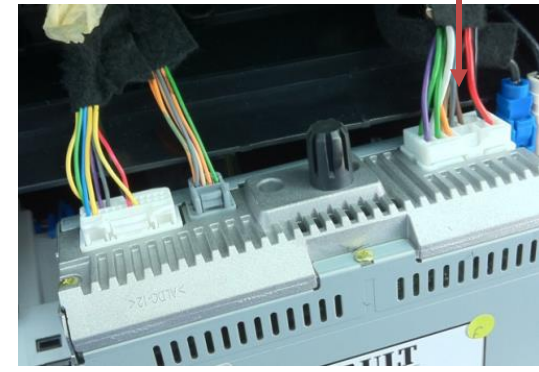
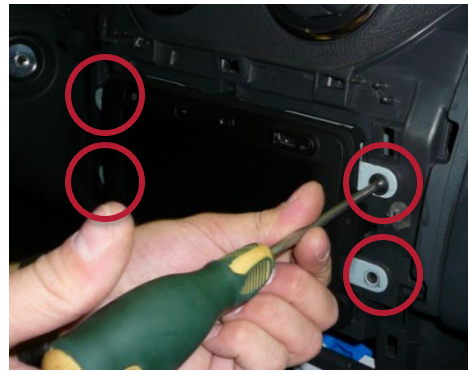
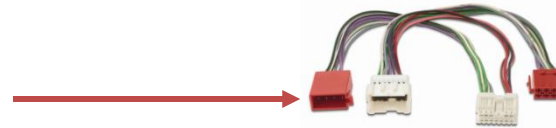

VIII. ASSEMBLING THE REAR SPEAKER DRIVERS

Connector

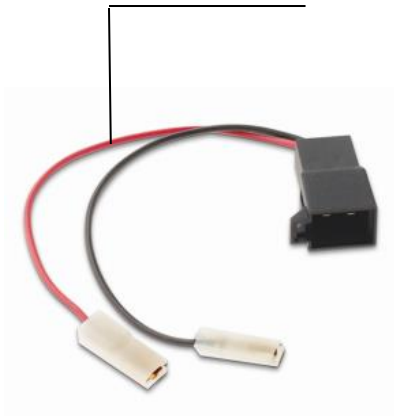

Speaker driver



Installed speaker driver



IX. PREPARING THE SUBWOOFER

Equipment required for installing the subwoofer:

Ground cable

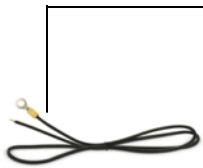

Power cable



Crimp sleeve

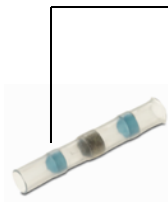

Power connector

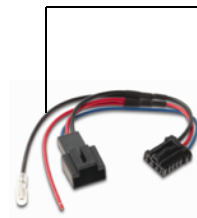

Subwoofer cable with remote control



Adapter

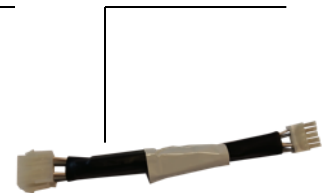

Ibus 2.1



Extension cable



Head unit – subwoofer interconnect cable



Hook-and-loop fasteners (e.g. Velcro)



Connectors

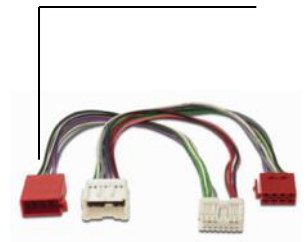

IX. PREPARING THE SUBWOOFER

1. Glue the two strips of hook-and-loop fasteners as shown.

Note:
be careful not to cover up the serial number.

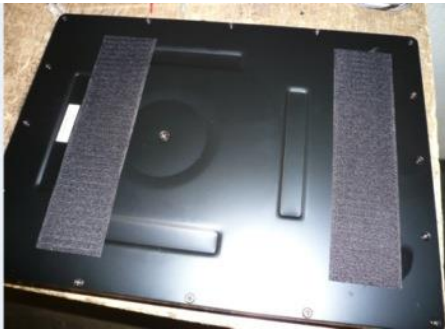

2. Connect the extension cable to the head unit - subwoofer interconnect cable.

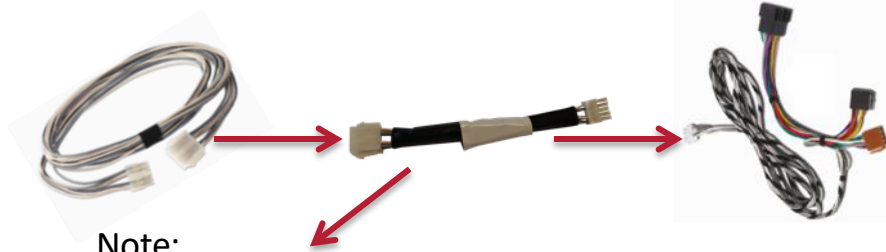

Note:
the adapter can only be used on an original head unit

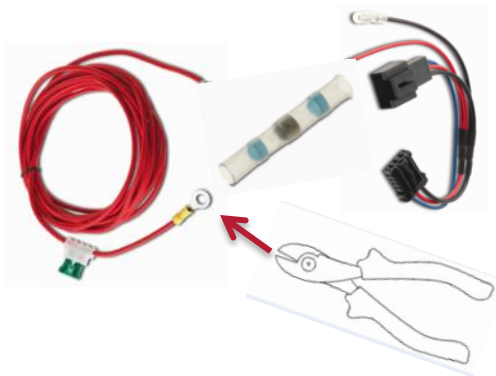

3. Cut off the terminal and splice.

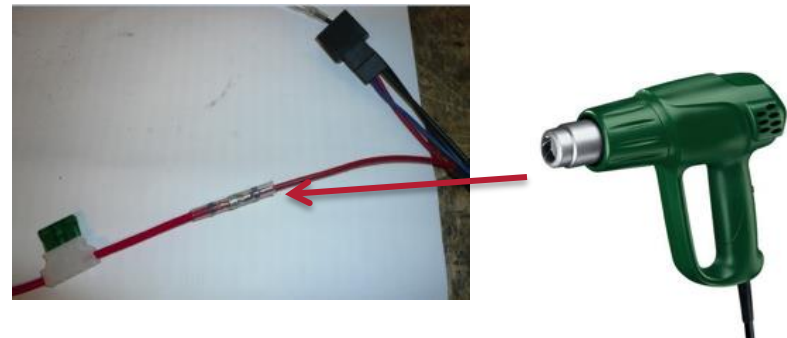

X. POSITIONING AND ADJUSTING THE SUBWOOFER



Under left side seat
(any versions)



Only Duster 4x4
(under the inner bottom of the trunk)

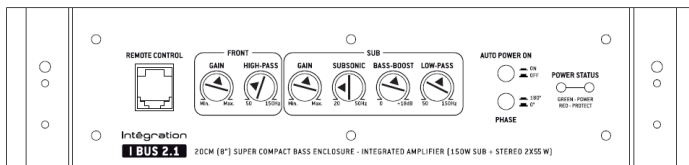

Auto Power = ON
Phase = 0°

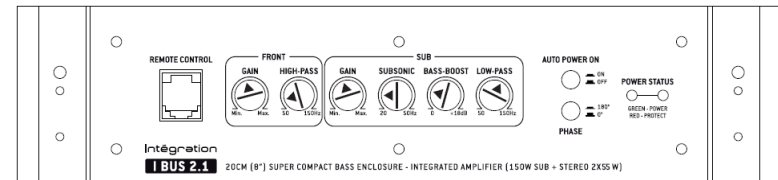

Auto Power = ON
Phase = 0°

XI. INSTALLING THE SUBWOOFER

1. Run the power connector + interconnect cable + remote control cable from the subwoofer to the head unit.

Connect the power connector to the 12V power socket.



XI. INSTALLING THE SUBWOOFER

2. Remove the head unit and connect the connectors to the radio

A version



B version

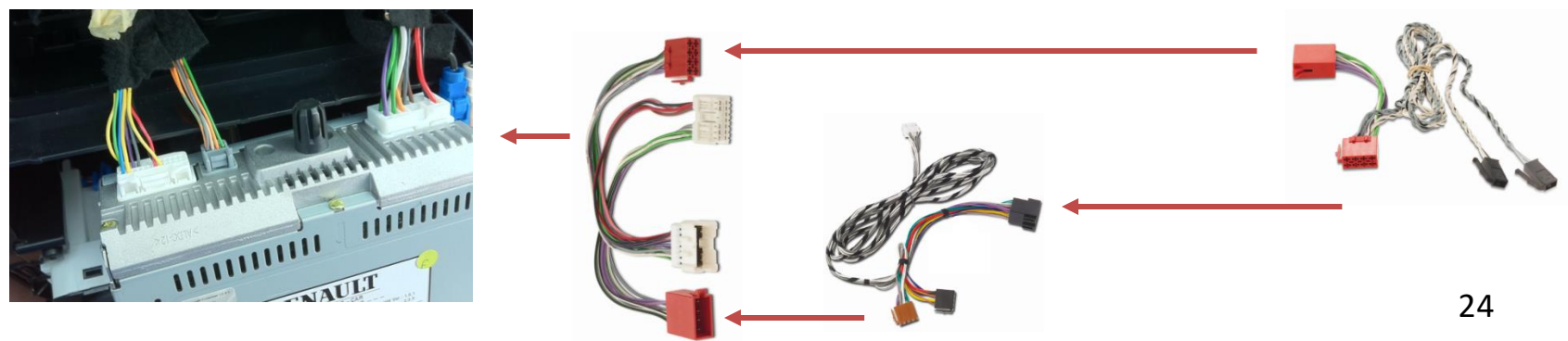

XI. INSTALLING THE SUBWOOFER



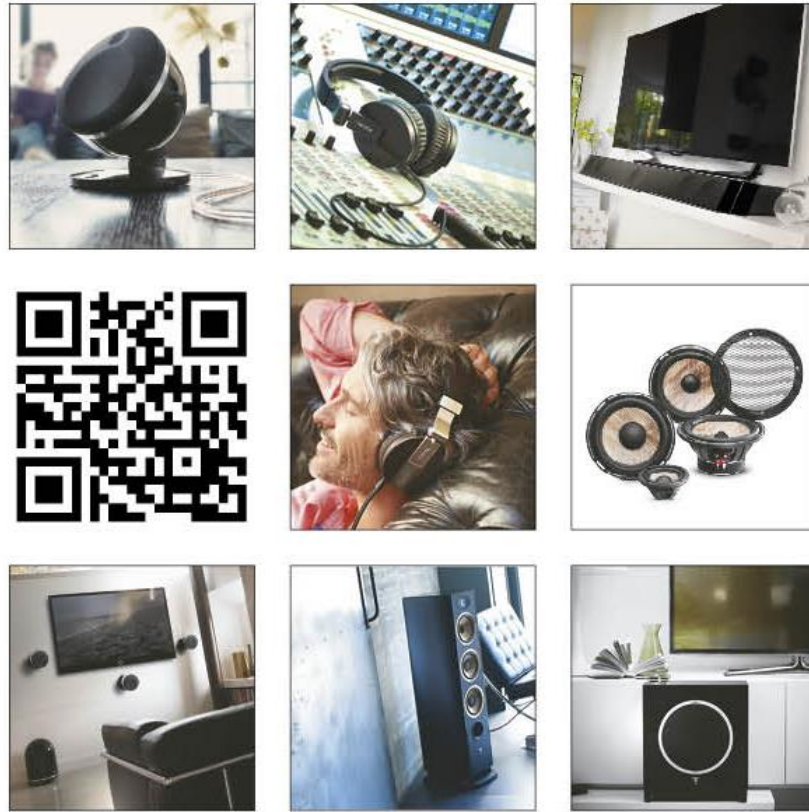





www.focal.com

FOCAL® is a trademark of FOCAL-JMLAB®
 