

# FOCAL/RENAULT

INSTALLATION OF LIVE/PREMIUM KITS FOR  
Scenic IV - *October 2017*

---



**FOCAL** *INSIDE*

# RECOMMENDATIONS BEFORE INSTALLATION

Reset all car radio audio settings:

- Ambience = Natural
- Bass / Midrange / Treble settings = 0
- Loudness = OFF
- Fader and Balance = Centred

The speaker drivers require a break-in period (approximately 20 hours) before they reach optimal sound quality. Start with tracks without too much low frequencies at a low volume. Then turn the sound up little by little.

After this break-in period, you can fine-tune the audio settings as you please.



# I - UNBOXING AND LOCATION OF PARTS

Ibus 2.1

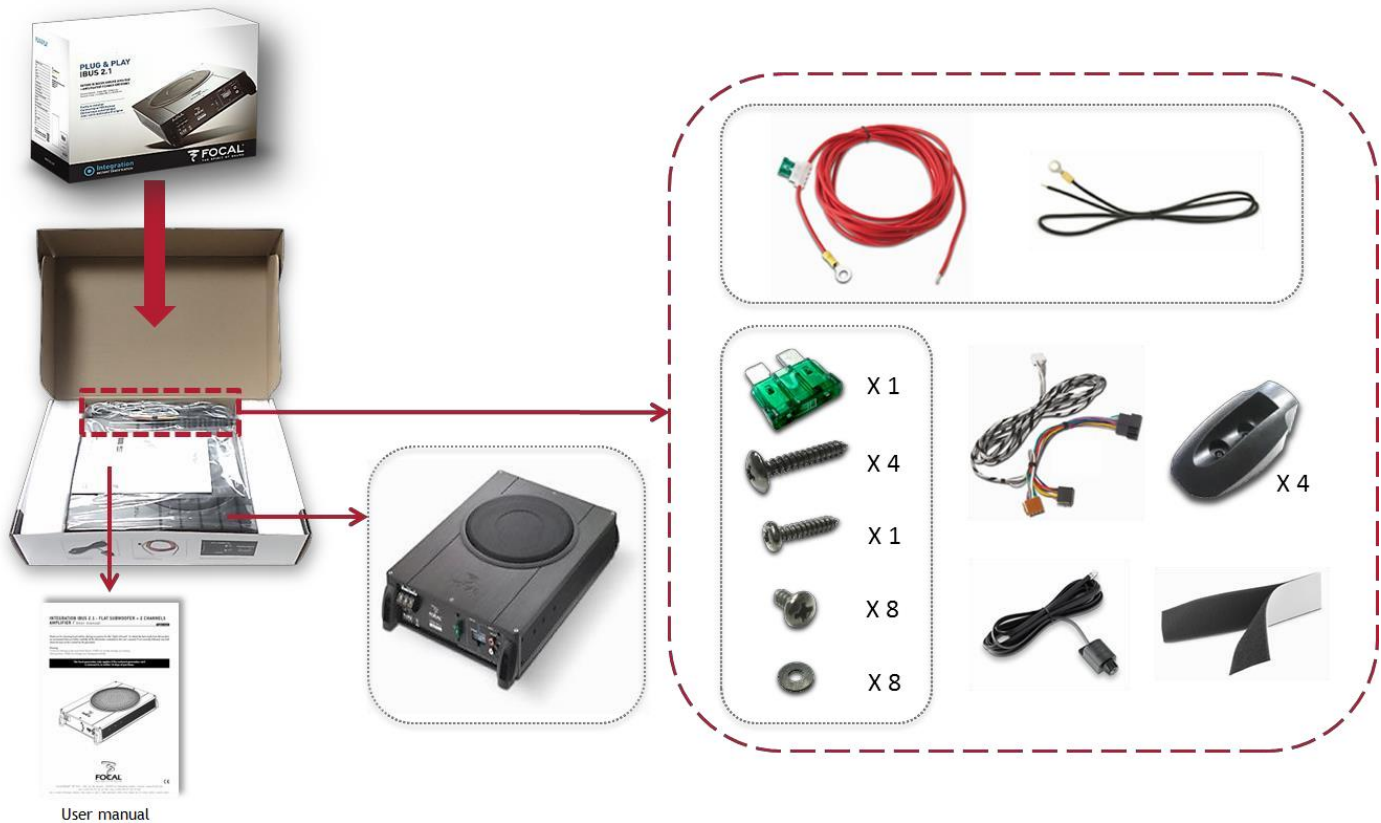

# I - UNBOXING AND LOCATION OF PARTS

IFRA165-4

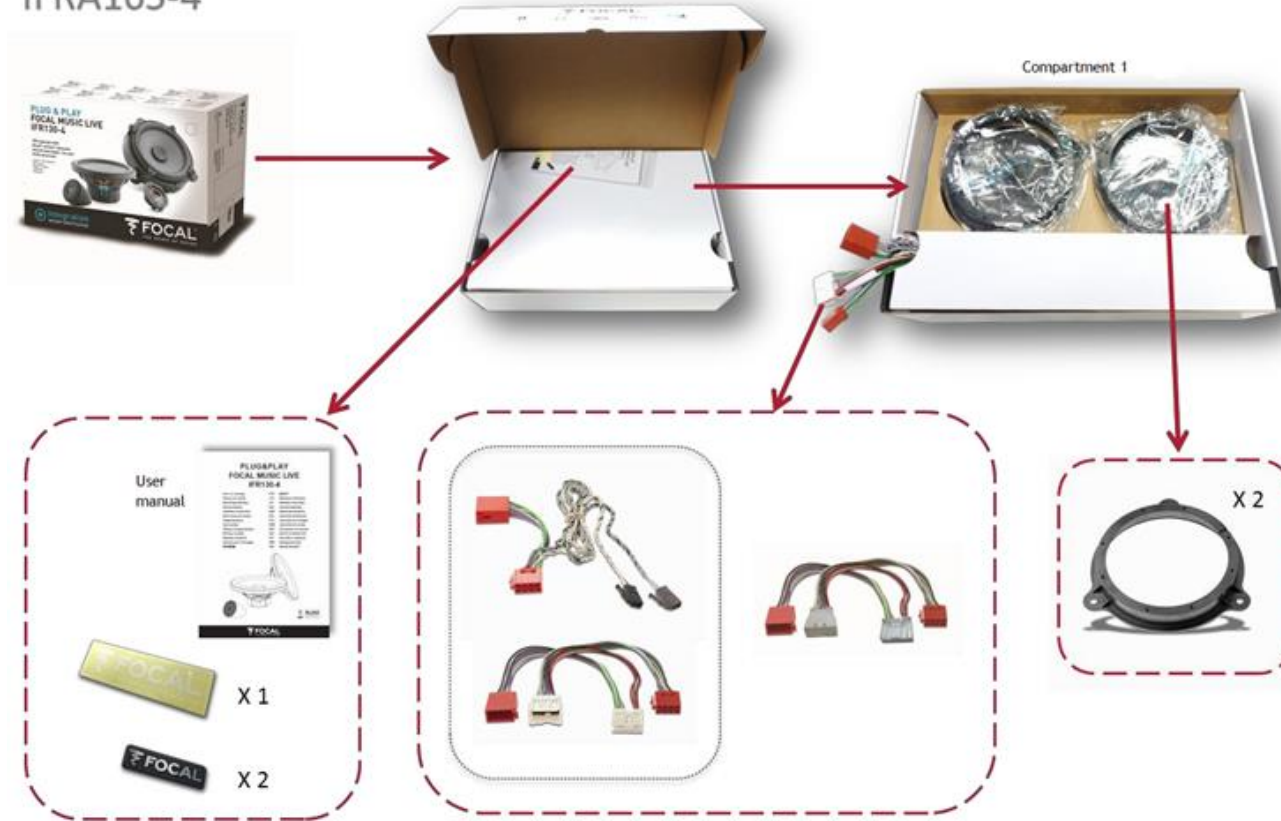

**FOCAL** *INSIDE*

# I- UNBOXING AND LOCATION OF PARTS

IFRA165-4

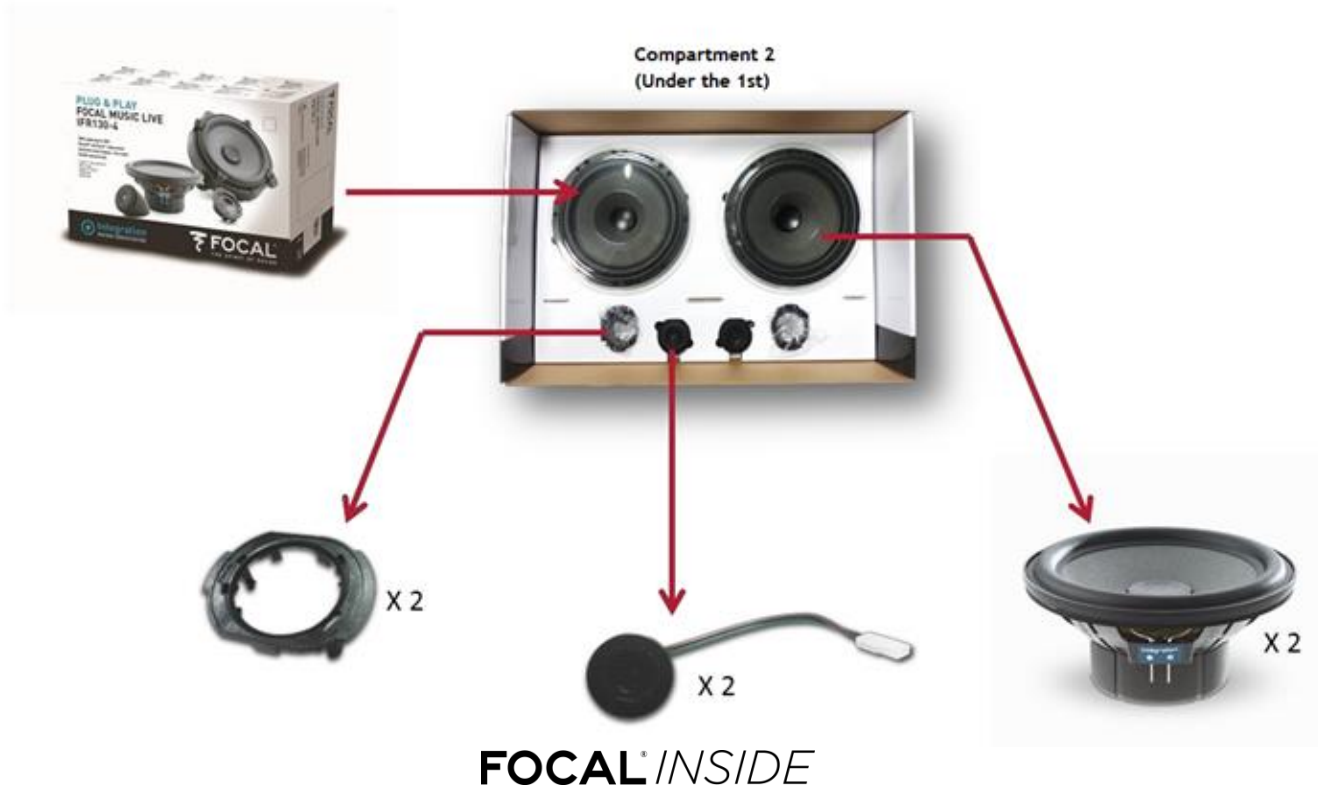

# I - UNBOXING AND LOCATION OF PARTS

IFRA165-4

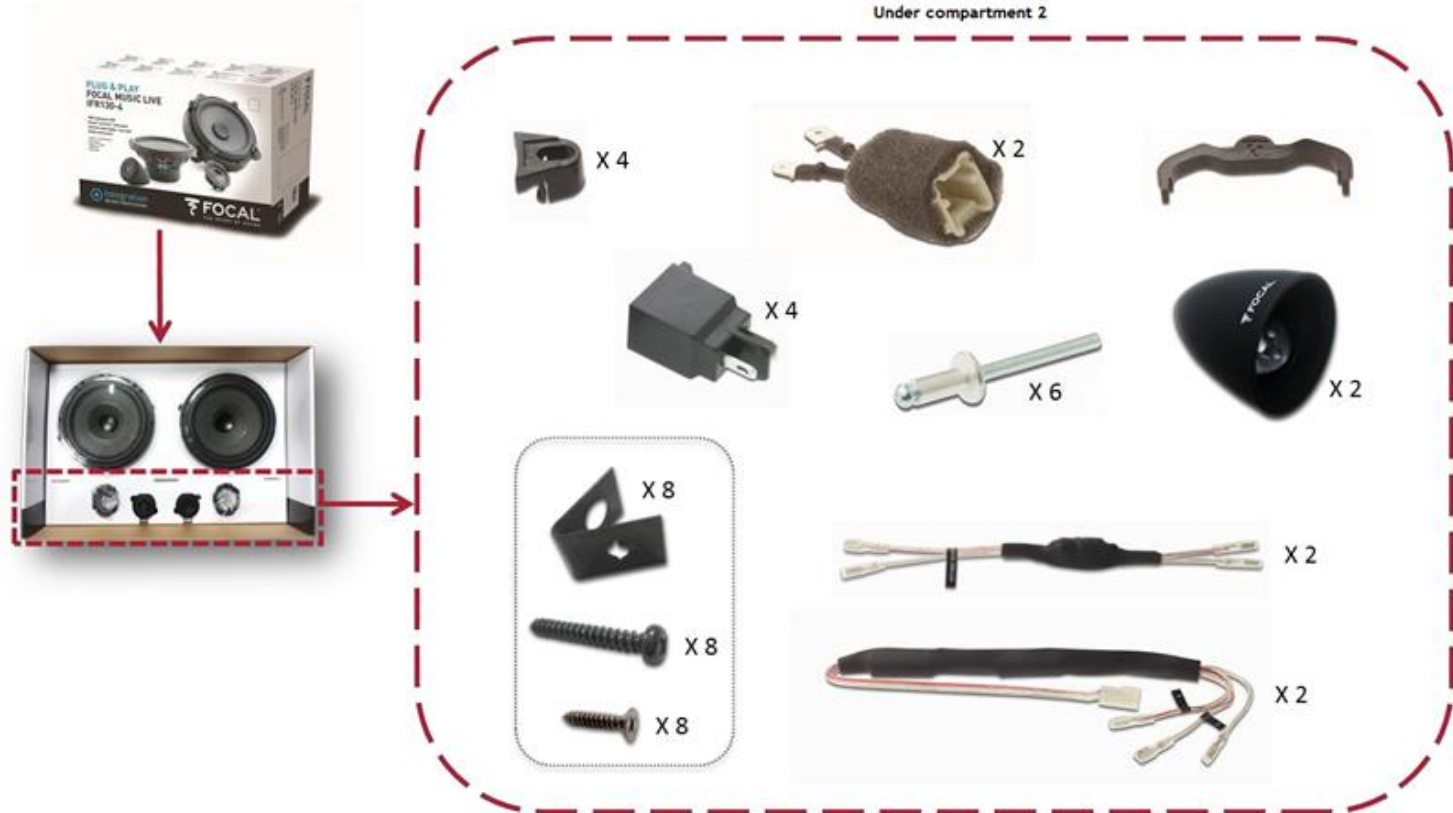

**FOCAL** *INSIDE*

## II - ASSEMBLING THE FRONT SPEAKER DRIVERS

1. Equipment required for assembling the woofer





# II - ASSEMBLING THE FRONT SPEAKER DRIVERS

## 2. Connections

a. Insert the cable into the notch



b. Before you screw, make sure that the two logos are aligned



c. Screw the 4 screws



D. Block the crossover



# III - INSTALLING THE FRONT SPEAKER DRIVERS

1. Remove the front door panel



# III - INSTALLING THE FRONT SPEAKER DRIVERS

1. Remove the front door panel ( Using prying tools )

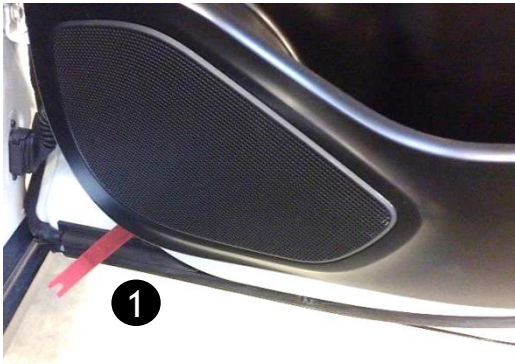

# III - INSTALLING THE FRONT SPEAKER DRIVERS

2. Remove the original speaker driver

a. Drill the head of each rivet.

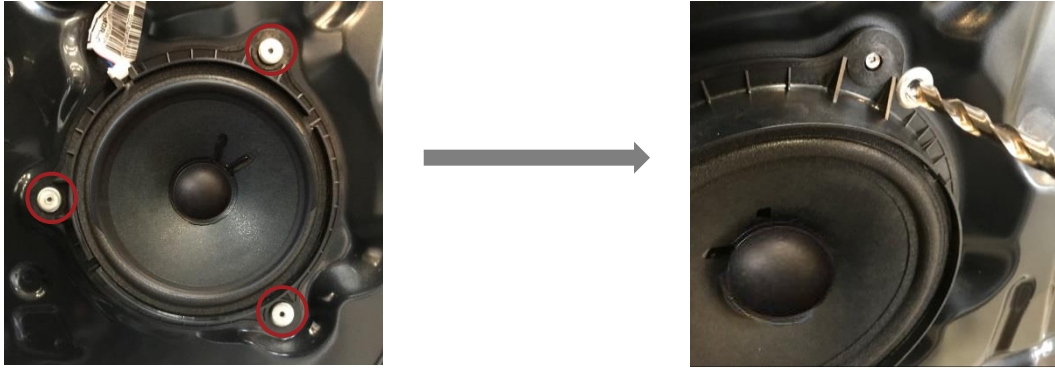

b. Remove the rivet body from the inside.



 **Note:** Use gloves during step b.

# III - INSTALLING THE FRONT SPEAKER DRIVERS

## 3. Installing your Focal speaker

- a. Rivet and connect the Focal speaker driver.

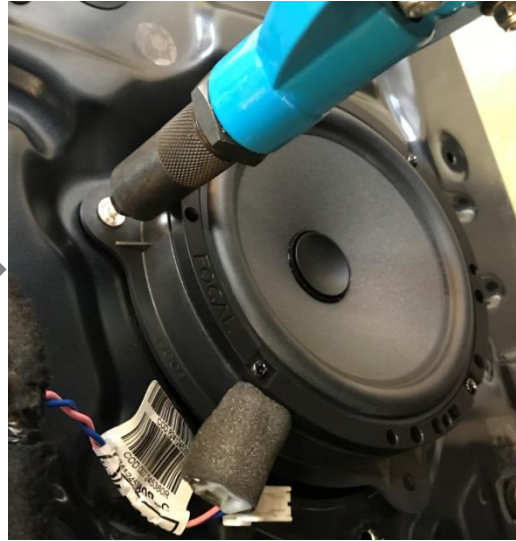

## IV - ASSEMBLING THE TWEETER

1. Equipment required for assembling the tweeter

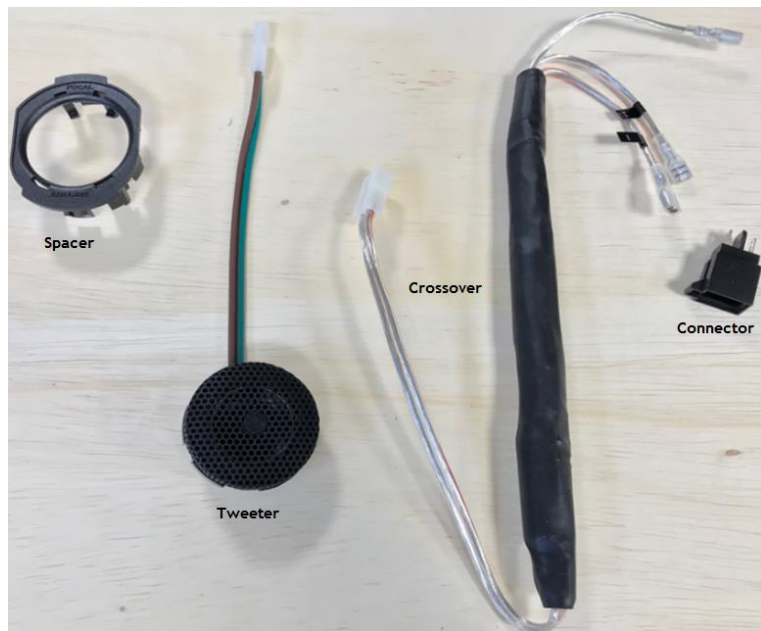

2. Remove the tweeter's grille by simply unclipping it

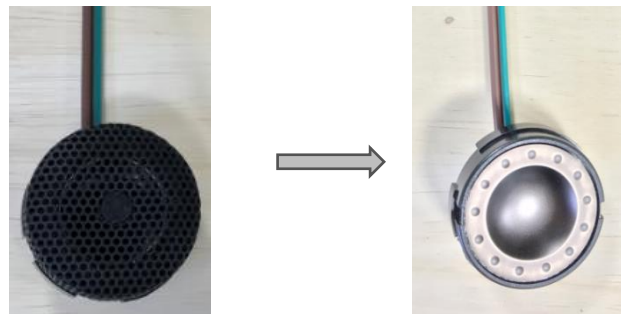

## IV - ASSEMBLING THE TWEETER

3. Slot the tweeter into the spacer making sure it's the right way up

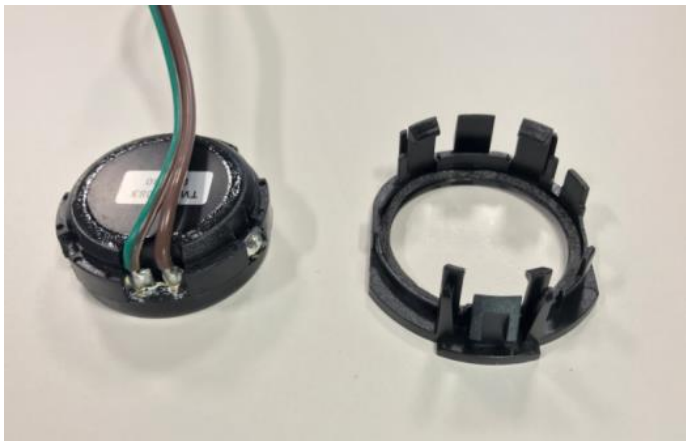

**Note:** Dispose the parts in this very position.

4. Connect at position 2



**Note:** Position 1 is not used in this set up

# V - INSTALLING THE TWEETER

a. Remove the tweeter grille.

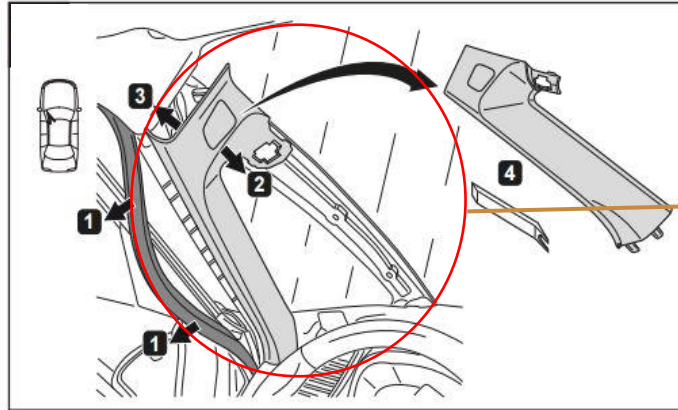
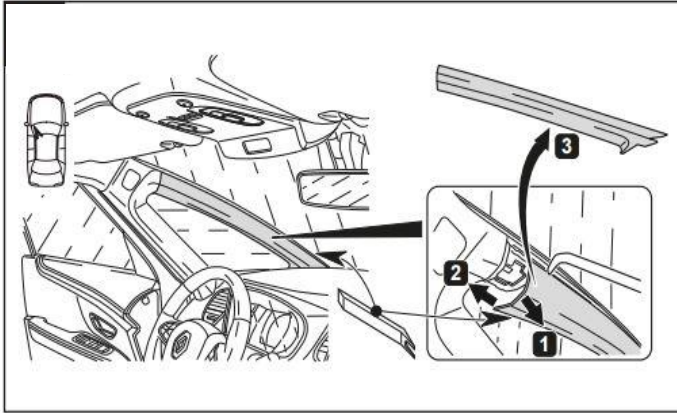

b. Remove the tweeter.



**FOCAL** *INSIDE*



# V - INSTALLING THE TWEETER

c. Connect the Focal tweeter and clip it into its housing.

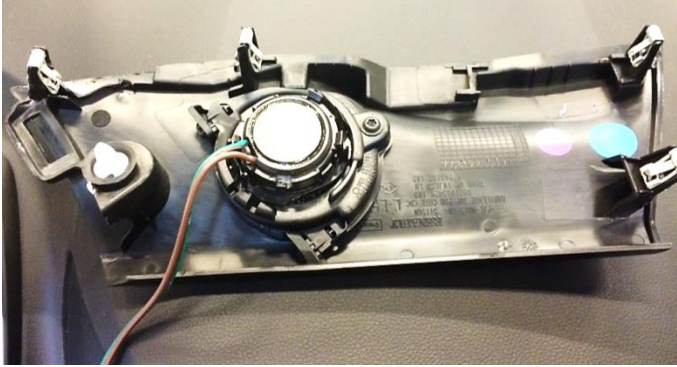

d. Connect the crossover as shown on the picture.



e. Stick the logo included with the kit on to the grille.



# VI - ASSEMBLING THE REAR SPEAKER DRIVERS

1. Remove the rear door panel



## VI - ASSEMBLING THE REAR SPEAKER DRIVERS

1. Remove the rear door panel ( Using prying tools )



# VI -ASSEMBLING THE REAR SPEAKER DRIVERS

## 2. Remove the original speaker driver

### a. Drill the head of each rivet.

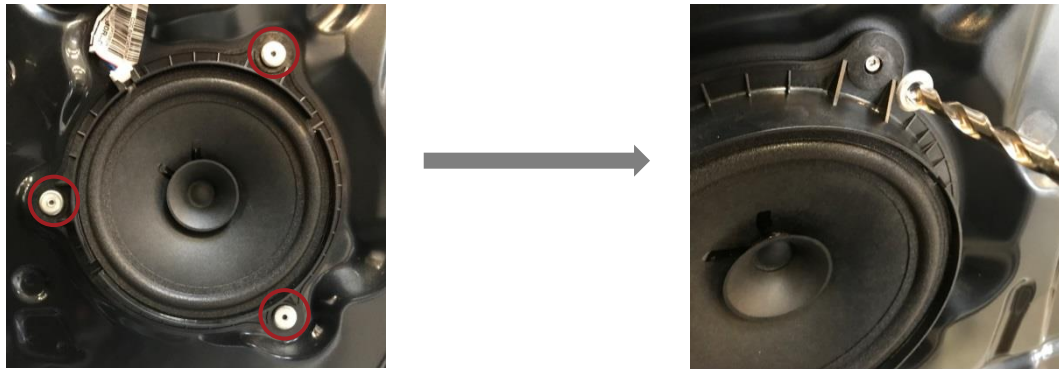

### b. Remove the rivet body from the inside.

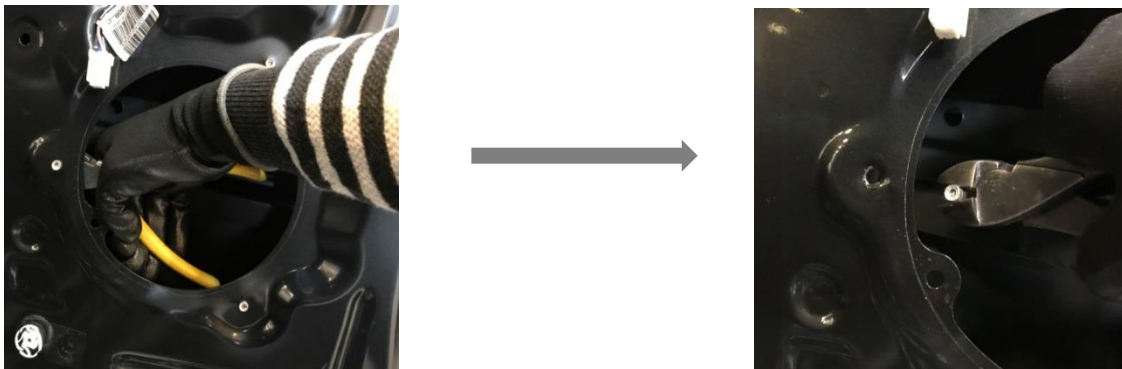

 **Note:** Use gloves during step b.

# VI - ASSEMBLING THE REAR SPEAKER DRIVERS

## 3. Installing your Focal speaker

a. Rivet and connect the Focal speaker driver.

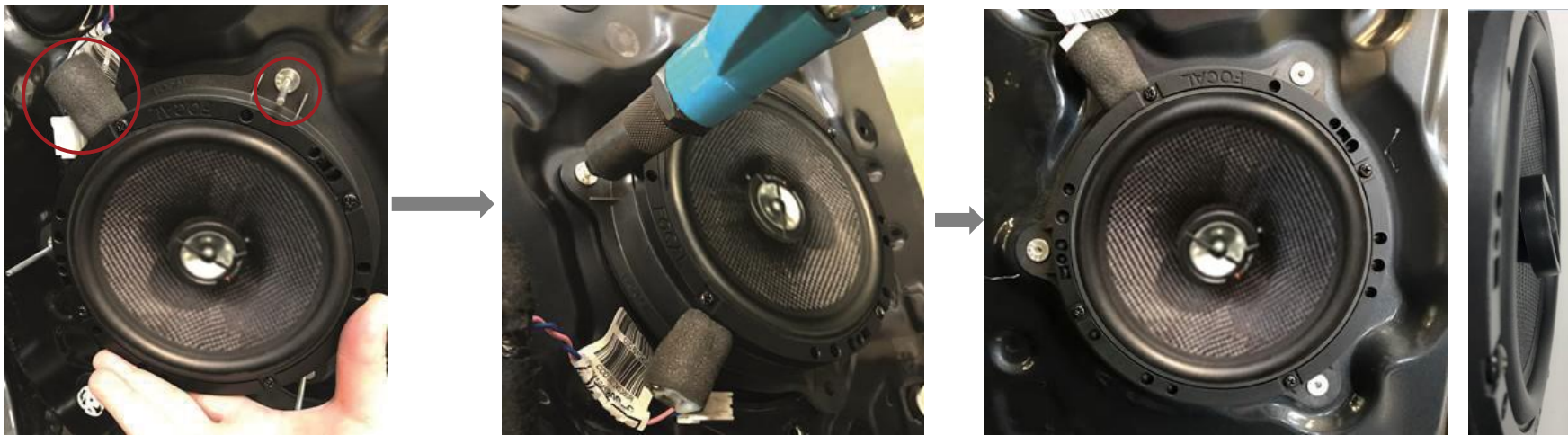

**Note:** Orientate the tweeter by turning it up or down.

# VII - PREPARING THE SUBWOOFER

## 1. Equipment required for installing the subwoofer

Ground cable



Power cable



Heat shrinkable sleeve



Power connector



Subwoofer cable with remote control



Adapter



Ibus 2.1



Extension cable



Head unit - subwoofer interconnect cable



Hook-and-loop fasteners (e.g. Velcro®)



Connectors



# VII - PREPARING THE SUBWOOFER

## 1. Cabling preparation

a. Cut the cable where indicated.

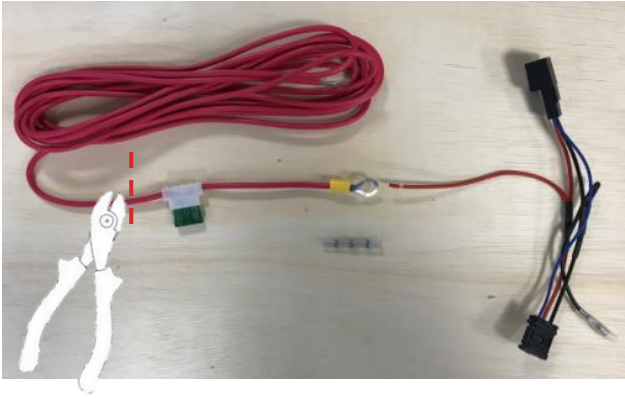

b. Place the heat shrinkable sleeve over the stripped parts of the cables.

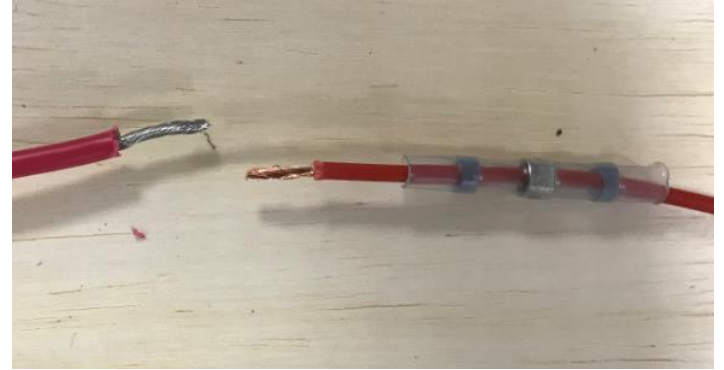

c. Use a heat gun to heat the heat shrinkable sleeve.

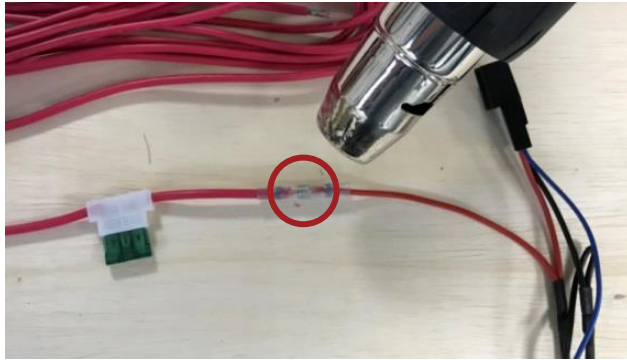

## VII - PREPARING THE SUBWOOFER



d. Connect the adapter to the extension cable.

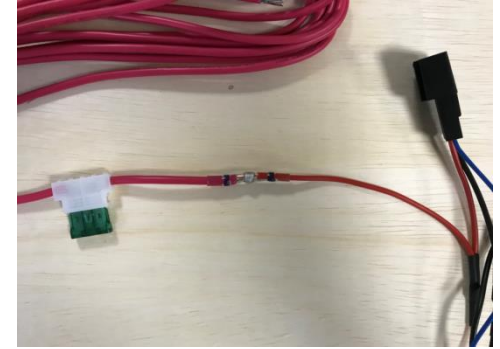

e. Place the subwoofer without connecting it.



f. Tape the cables together every 20 cm.

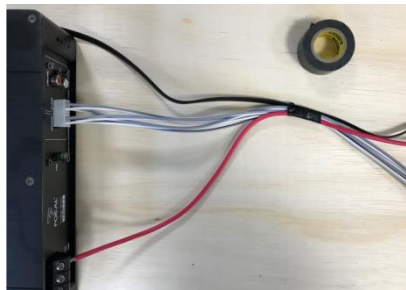

g. Keep slack for the cable's passage on the side of the head unit.

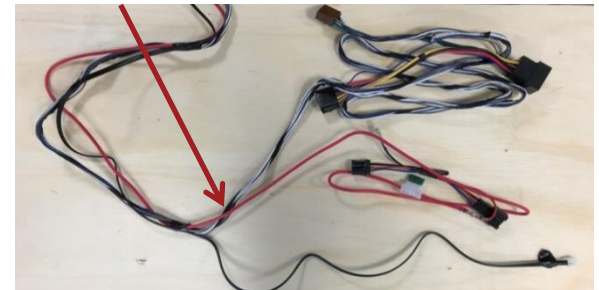



# VIII - INSTALLING THE SUBWOOFER

1. Remove the left side panel to connect power and ground

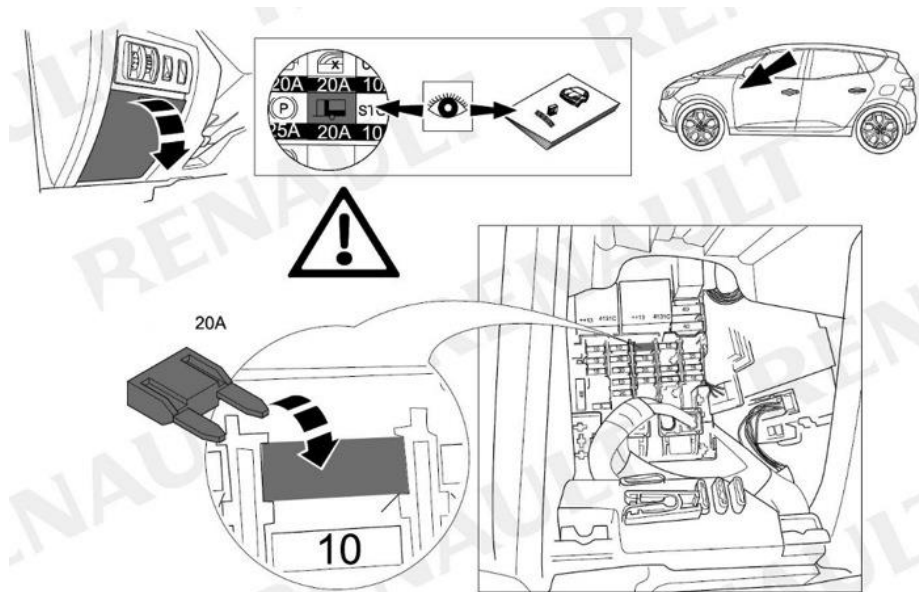
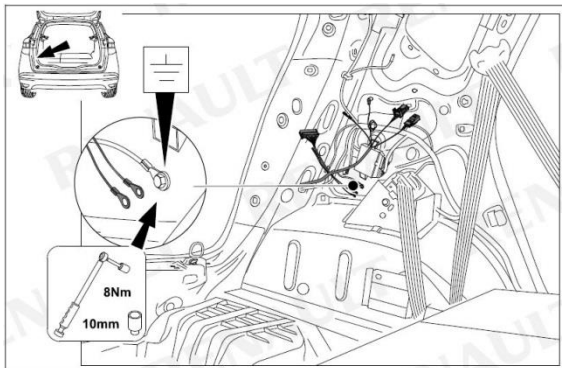

# VIII - INSTALLING THE SUBWOOFER

## 2. Braid and connection

a. Braid passage from the back to the front ( glove compartment) on the right side.



# VIII - INSTALLING THE SUBWOOFER

## 2. Braid and connection

b. Remove the entire glove compartment and put it aside.



**Note:** Be careful not to cover the serial number.



**Note:** Unclip the cap to free the counter spring.



# VIII - INSTALLING THE SUBWOOFER

## 2. Braid and connection

c. Cut the top of the glove compartment to access to the head unit connection (*About 95mm x 95mm*).

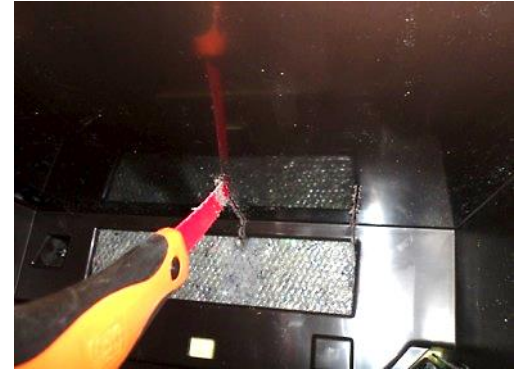
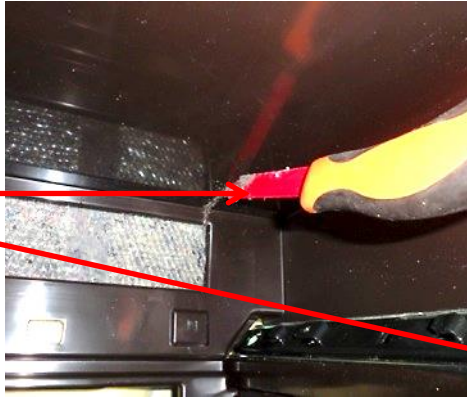

**Note:** Be careful not to cut too deeply ( the head init connection is on the top of the glove compartment .

# VIII - INSTALLING THE SUBWOOFER

## 2. Braid and connection

d. Connect the subwoofer power connector with the adapter.

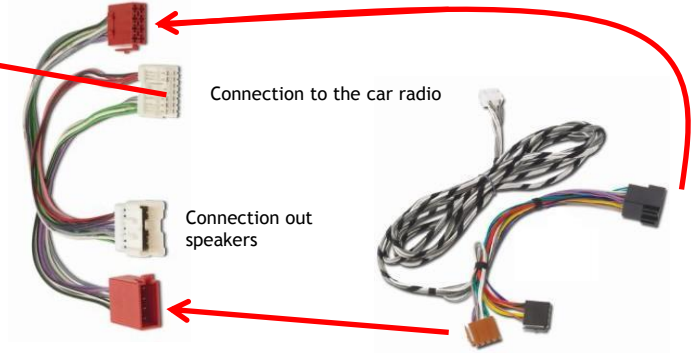
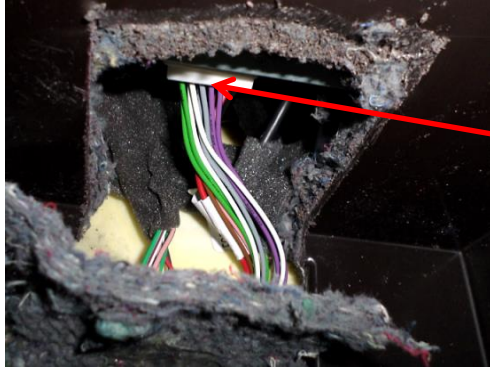

# VIII - INSTALLING THE SUBWOOFER

## 3. Positioning the subwoofer

a. Scénic 5 seats version :



b. Scénic 7 seats version :



## VIII - INSTALLING THE SUBWOOFER

e. Cabling (back).



f. Cabling (front - remote control).



# VIII - INSTALLING THE SUBWOOFER

g. Subwoofer settings.

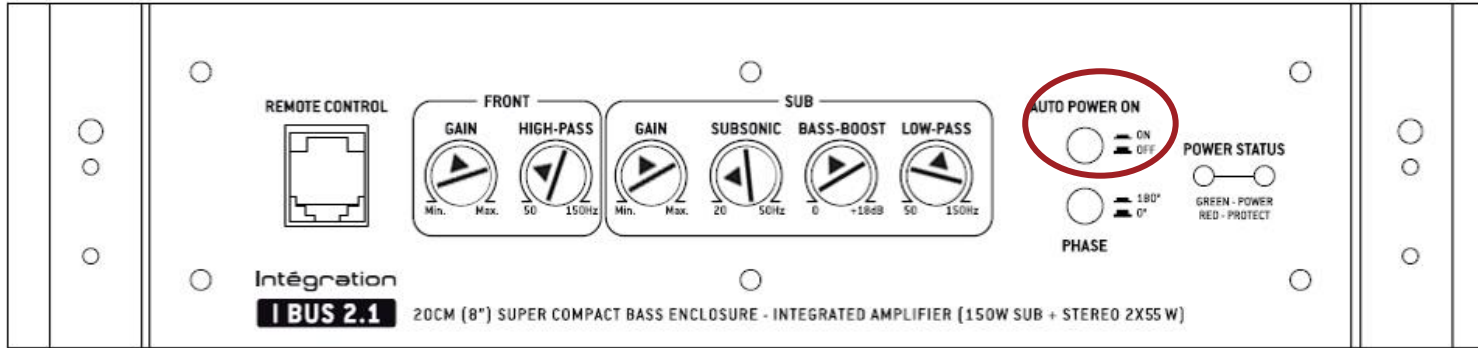

Auto Power = ON  
Phase = 0°

Phase: 0 or 180, this depends on many parameters, so it is advisable to try both positions without altering any other settings, and then to choose the one which sounds best.



## VIII - INSTALLING THE SUBWOOFER

### 5. Installing the remote control



Fix the remote control with glue or Velcro® (recommended).

# IX -AESTHETIC FINISH

## 6. Hide the hole

- a. Use the hook-and-loop fasteners left (not used to fix the subwoofer) to close the hole of the glove compartment.

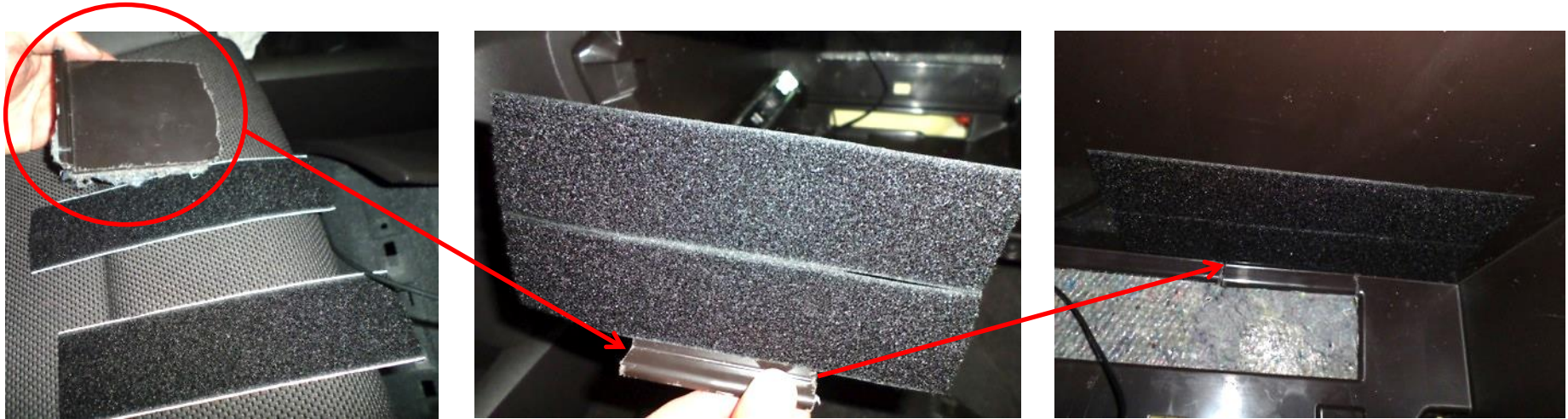

**FOCAL**<sup>®</sup> *INSIDE*

[www.focal-inside.com](http://www.focal-inside.com)