

FOCAL/RENAULT

MONTAGE DES KITS PREMIUM/LIVE POUR
Megane 4 - *Avril 2018*



FOCAL® *INSIDE*

RECOMMANDATIONS AVANT L'INSTALLATION

Réinitialiser tous les réglages audio de l'autoradio

- Ambiance = Neutre
- Réglages Graves/ Mediums/ Aigus= 0
- Loudness = OFF
- Fader et Balance = Centrés

Les haut-parleurs nécessitent une période de rodage (environ 20 heures) avant d'atteindre leur qualité sonore optimale. Commencez par des morceaux de musique sans basses excessives et à faible volume sonore puis augmentez le son petit à petit.

Une fois cette période terminée, vous pourrez affiner les réglages audio à votre convenance sur l'autoradio.

I - DEBALLAGE ET EMPLACEMENT DES PIECES

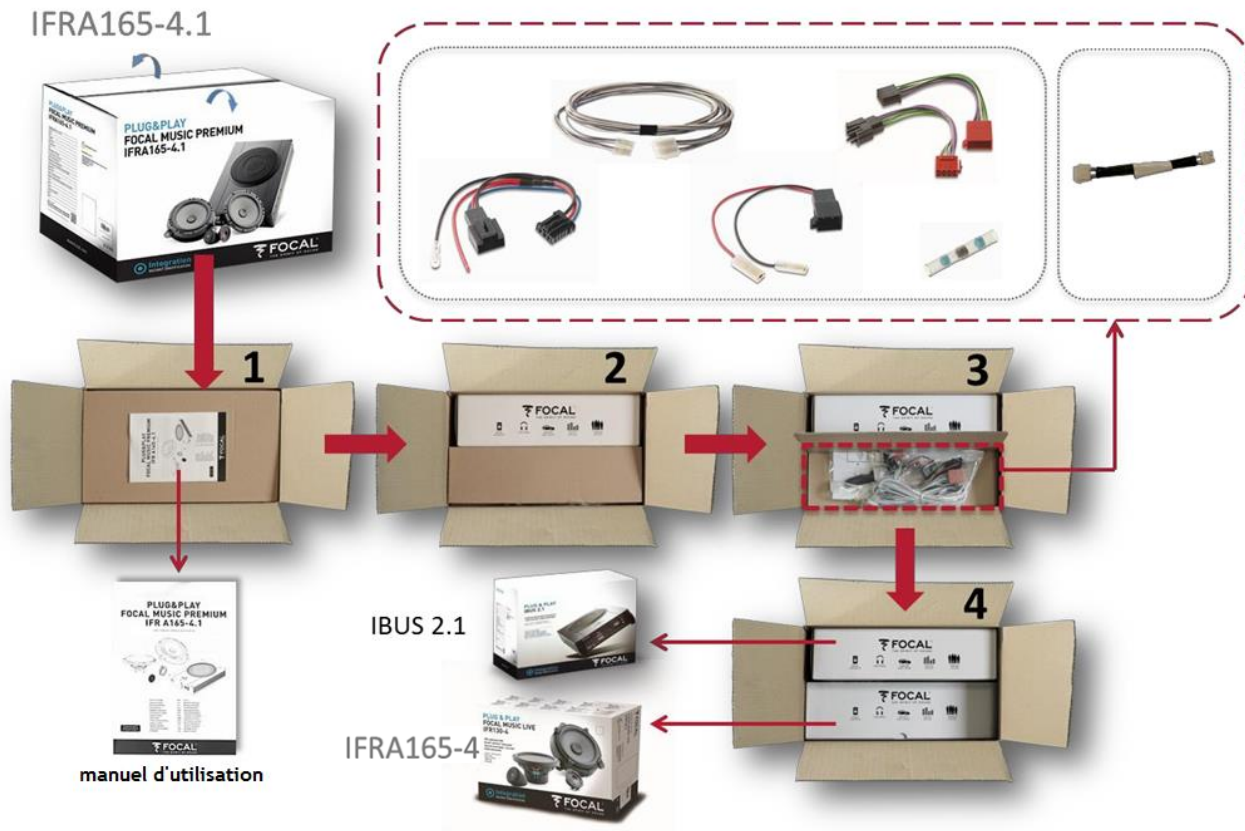

I - DEBALLAGE ET EMPLACEMENT DES PIECES

Ibus 2.1

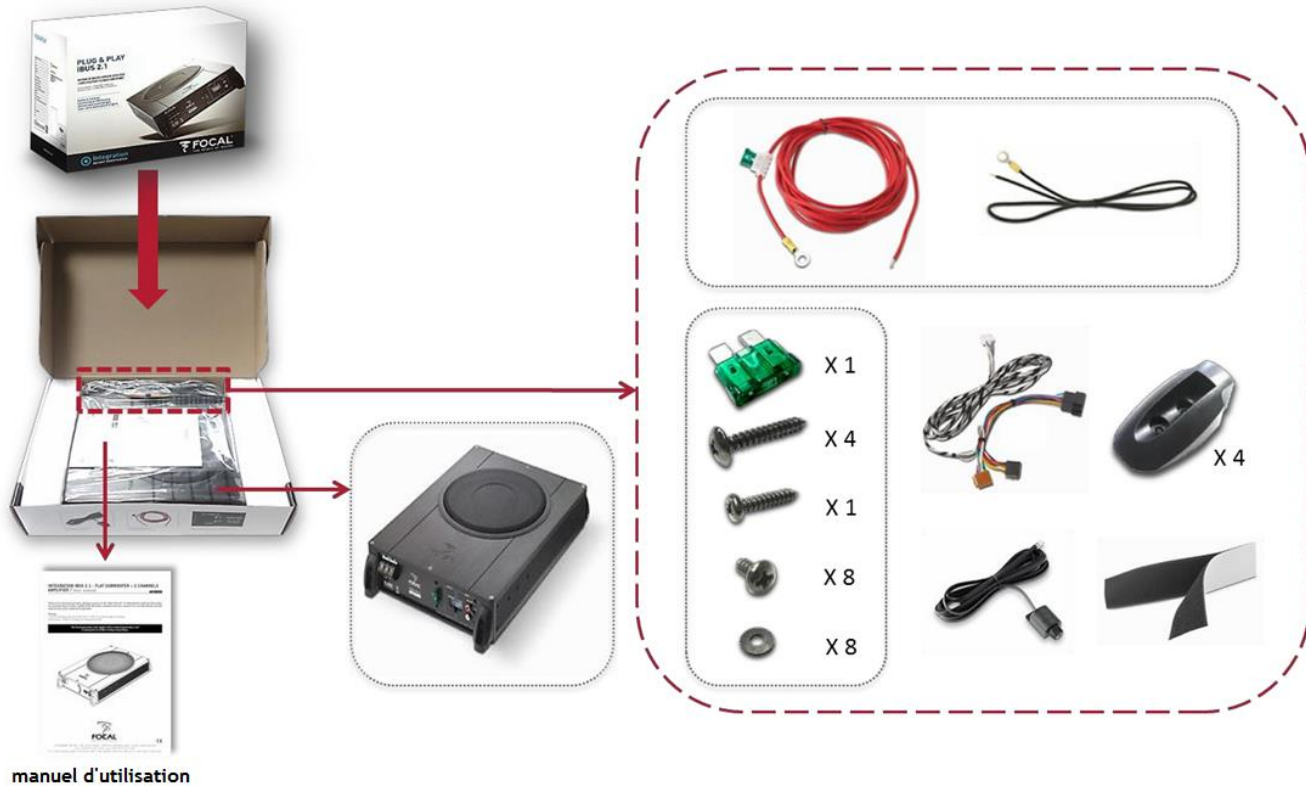

I - DEBALLAGE ET EMPLACEMENT DES PIECES

IFRA165-4

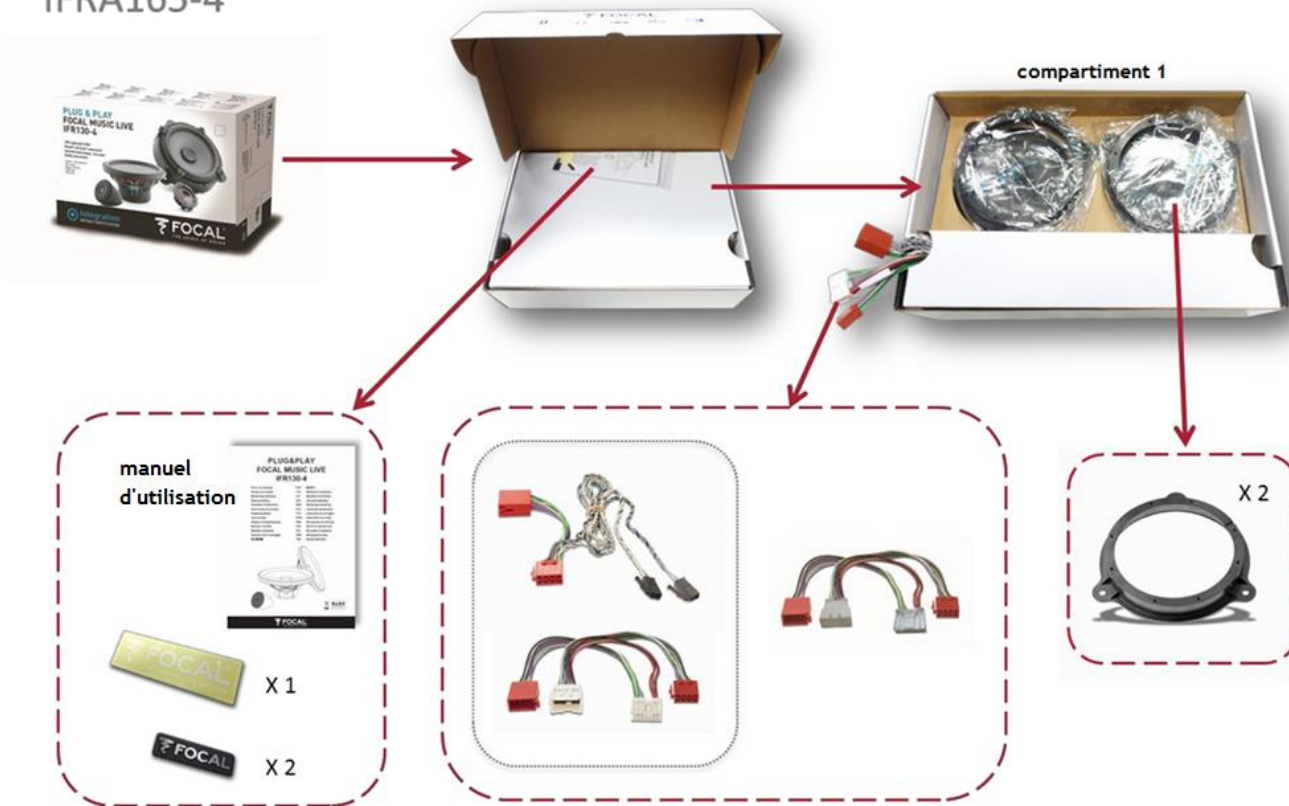

FOCAL[®]INSIDE

I- DEBALLAGE ET EMPLACEMENT DES PIECES

IFRA165-4

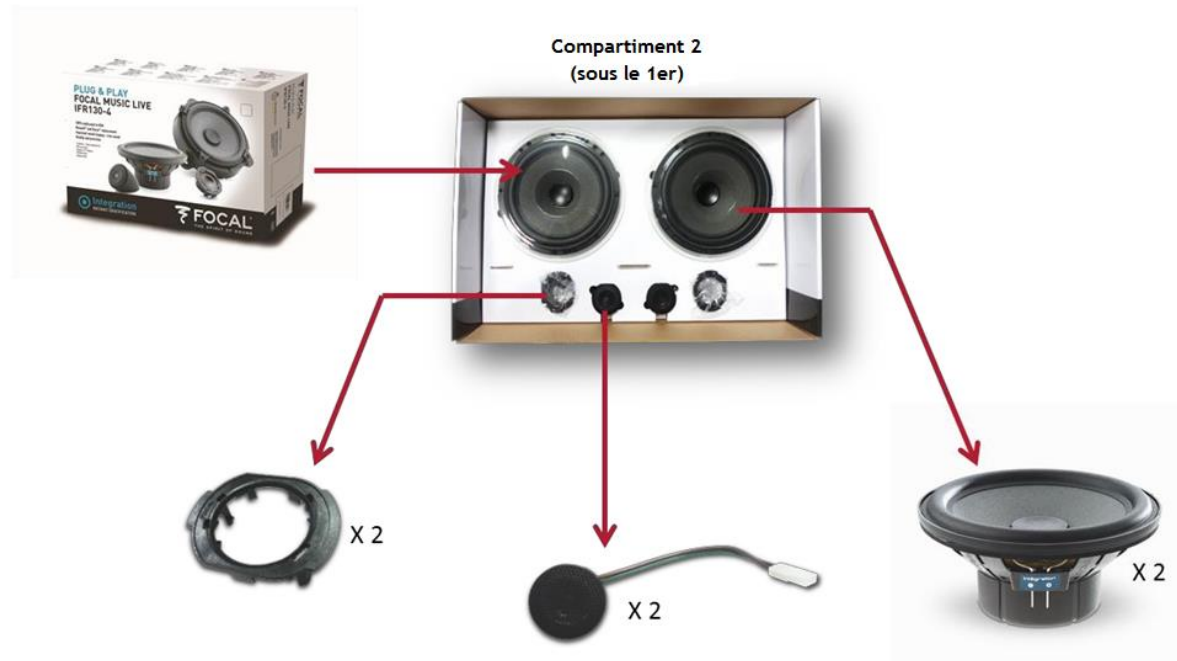

FOCAL[®]INSIDE

I - DEBALLAGE ET EMPLACEMENT DES PIECES

IFRA165-4



sous le compartiment 2

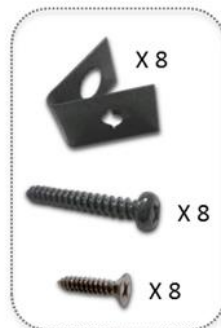

FOCAL[®]INSIDE

II - ASSEMBLAGE DES HAUT-PARLEURS AVANT

1. Pièces nécessaires à l'assemblage du woofer

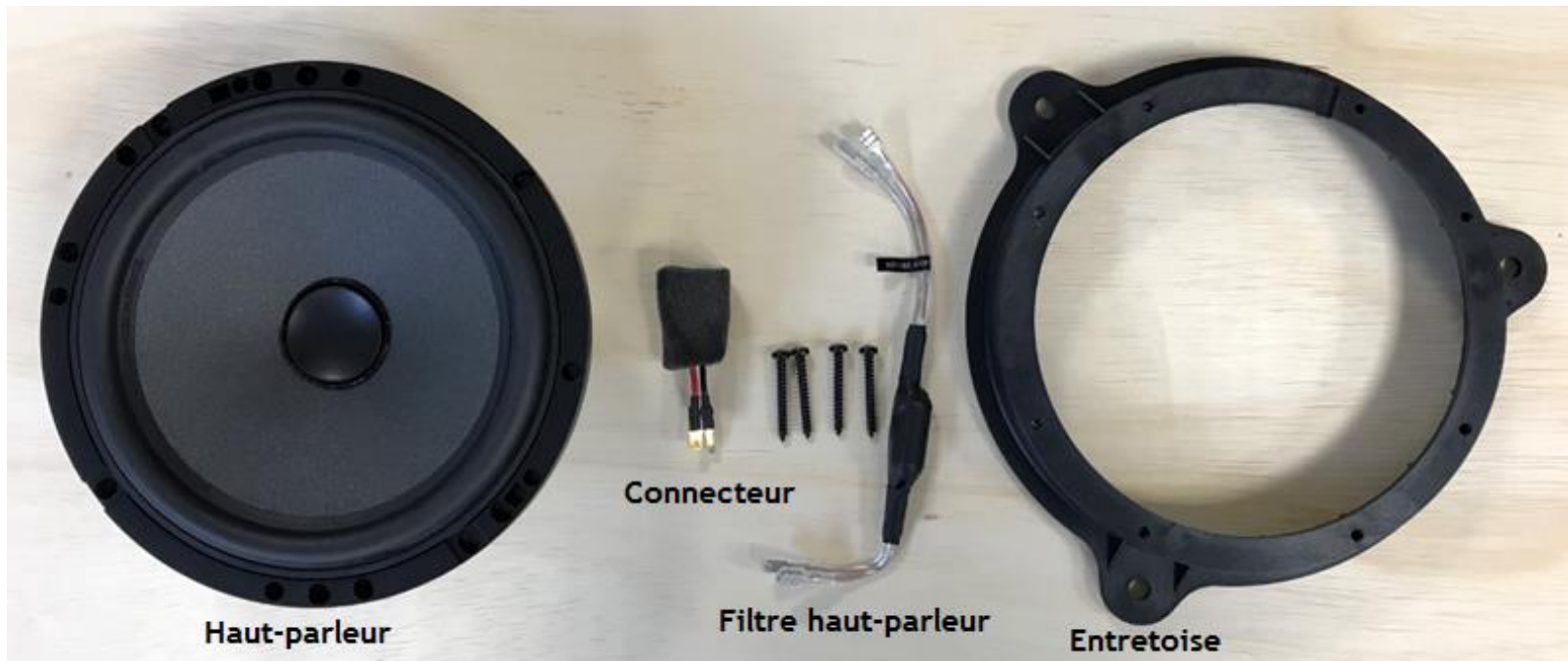

II - ASSEMBLAGE DES HAUT-PARLEURS AVANT

2. Assemblage haut-parleur

a. Insérez le câble dans l'encoche.



b. Avant de visser, assurez vous que les deux logos soient alignés.



c. Vissez les 4 vis.



d. Calez le filtre.



III - ASSEMBLAGE DES HAUT-PARLEURS AVANT

1. Démontez le panneau de la portière avant

a. Déclipper et dévisser puis retirer le panneau de porte

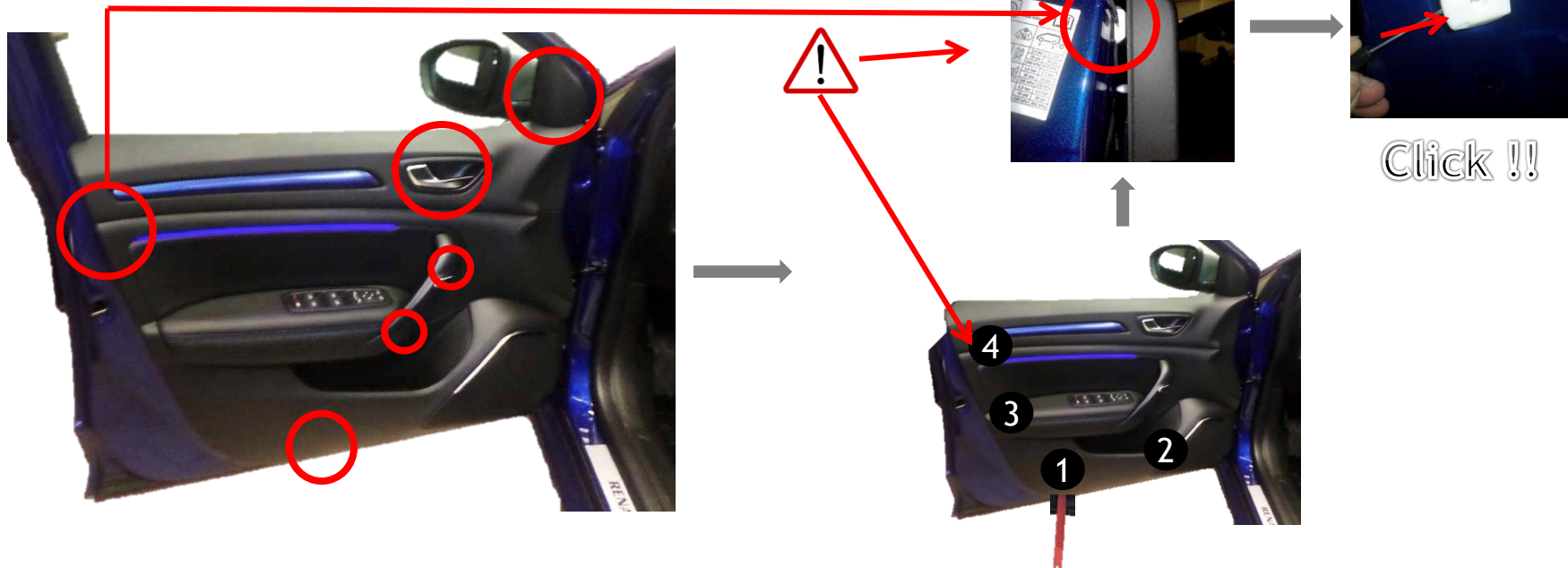

III - ASSEMBLAGE DES HAUT-PARLEURS AVANT

2. Retirez le haut-parleur d'origine

a. Percez la tête des 3 rivets supérieur.

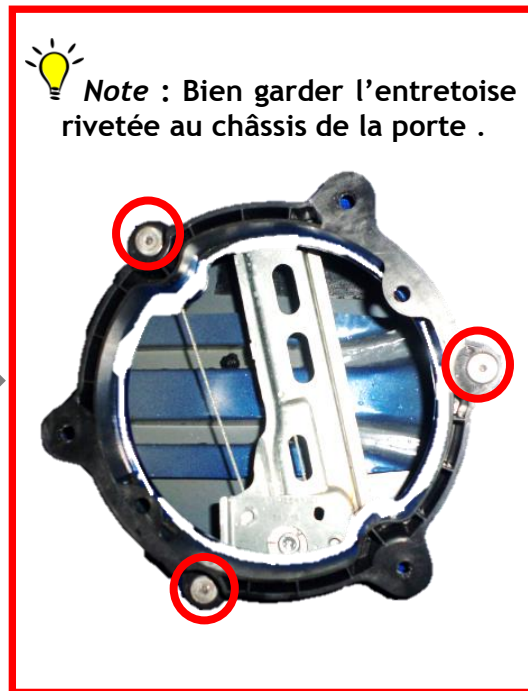

III - ASSEMBLAGE DES HAUT-PARLEURS AVANT

3. Installation du haut-parleur Focal

a. Riveter sur la cale et faites les branchements des haut-parleurs Focal.



+



=



Note : Il se peut que sur certaines versions les haut-parleurs soient vissés. Donc merci de ne pas prendre en compte les rivets

IV - ASSEMBLAGE DES TWEETERS

1. Pièces nécessaires à l'assemblage du tweeter

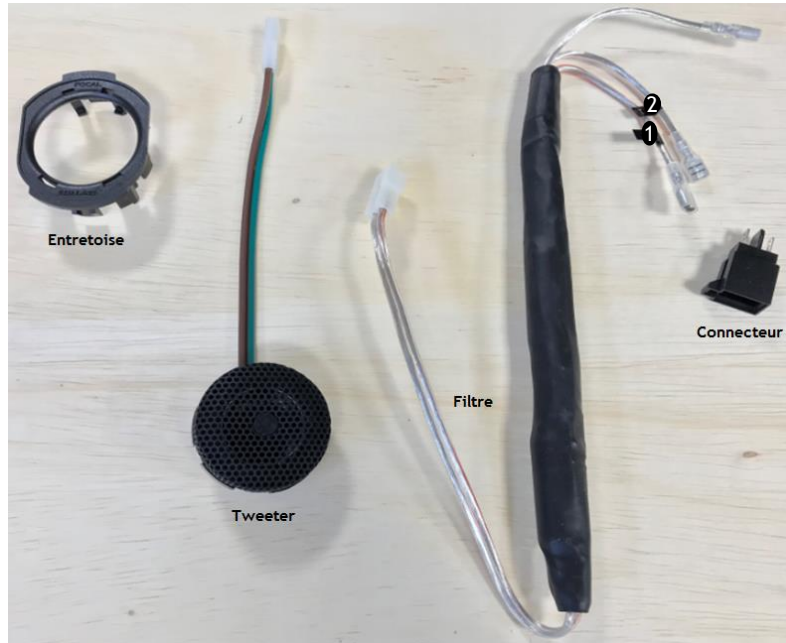

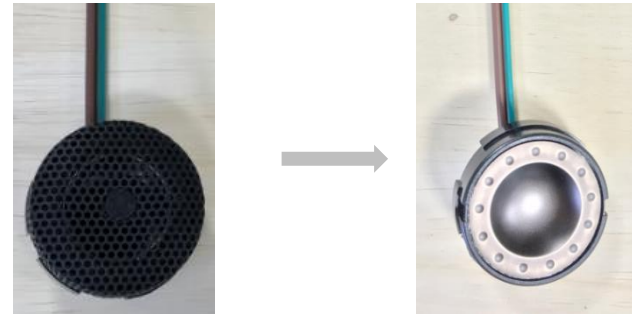

2. Enlevez la grille du tweeter en la dépliant

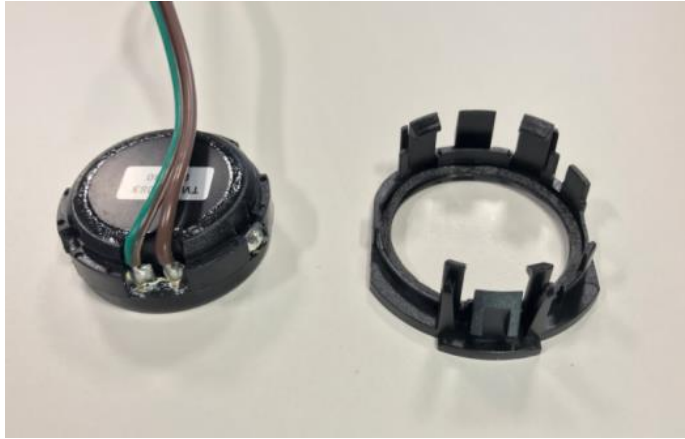

IV - ASSEMBLAGE DES TWEETERS

3. Insérez le tweeter dans l'entretoise



 **Note :** Les pièces doivent être disposées exactement comme sur la photo.

4. Connectez sur la position 2



 **Note :** La position 1 n'est pas utilisée dans cette configuration.

V - BRANCHEMENT DES TWEETERS

- 1 Enlevez la grille du tweeter



- 2 Retirez les tweeters d'origine



V - BRANCHEMENT DES TWEETERS

- 3 Connexion du filtre tweeter sur connecteur d'origine



- 4 Clipper le tweeter puis repositionner la grille



II bis - ASSEMBLAGE DES HAUT-PARLEURS ARRIERES

1. Pièces nécessaires à l'assemblage du woofer

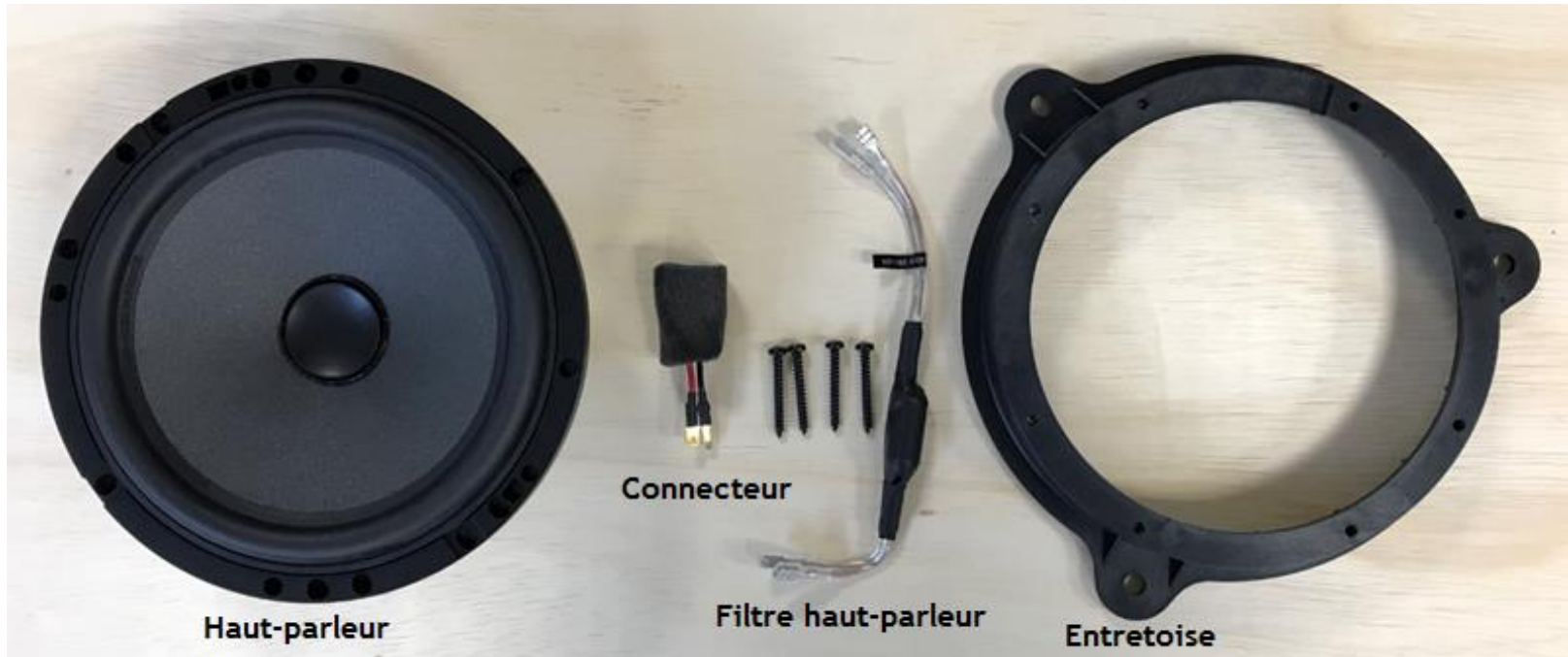

II bis - ASSEMBLAGE DES HAUT-PARLEURS ARRIERES

2. Assemblage haut-parleur

a. Insérez le câble dans l'encoche.



b. Avant de visser, assurez vous que les deux logos soient alignés.



c. Vissez les 4 vis.



d. Calez le filtre.



VI - MONTAGE DES HAUT-PARLEURS ARRIERES

1. Dévisser



2. Retirez la garniture plastique de la portière

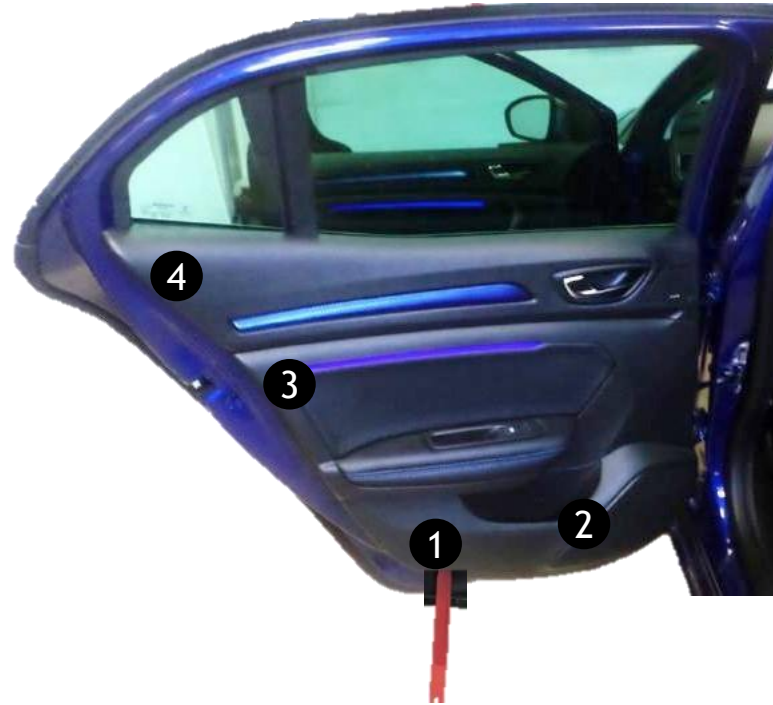

VI - MONTAGE DES HAUT-PARLEURS ARRIERES

3. Retirez le haut-parleur d'origine

a. Percez la tête des 3 rivets supérieur.

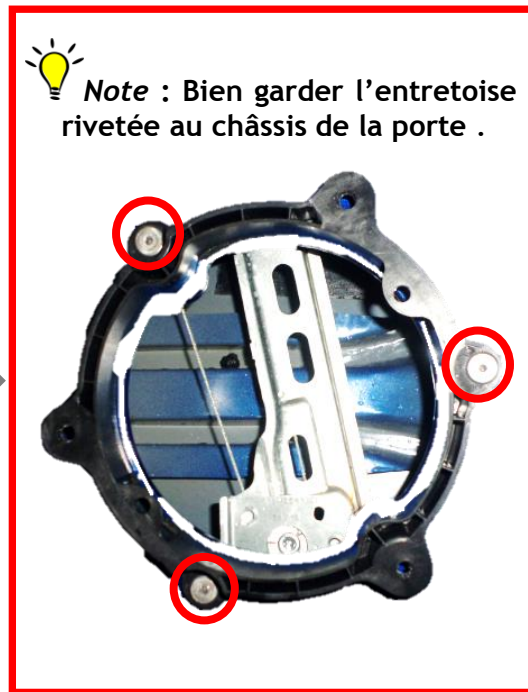

Note : Bien garder l'entretoise rivetée au châssis de la porte .

VI - MONTAGE DES HAUT-PARLEURS ARRIERES

4. Installation du haut-parleur Focal

a. Riveter sur la cale et faites les branchements des haut-parleurs Focal.



+



=



Note : Il se peut que sur certaines versions les haut-parleurs soient vissés. Donc merci de ne pas prendre en compte les rivets

VII - ASSEMBLAGE DES TWEETERS

1. Pièces nécessaires à l'assemblage du tweeter

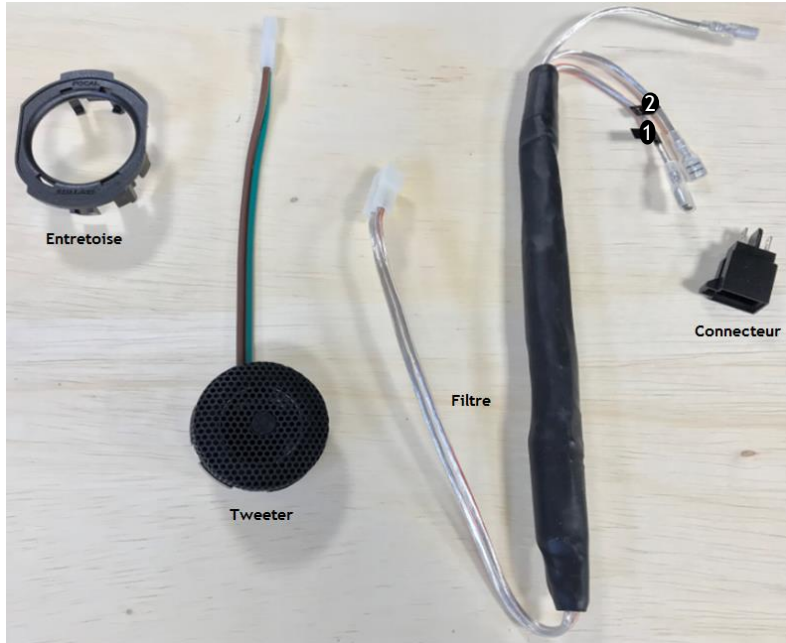

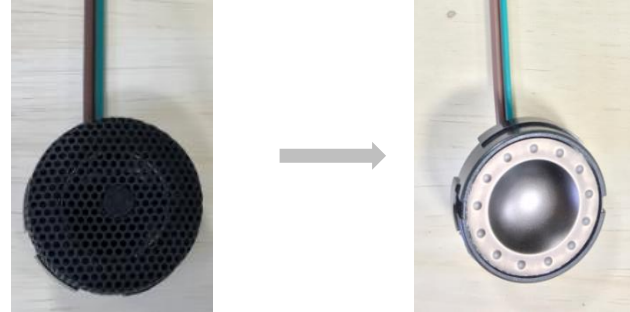

2. Enlevez la grille du tweeter en la dépliant

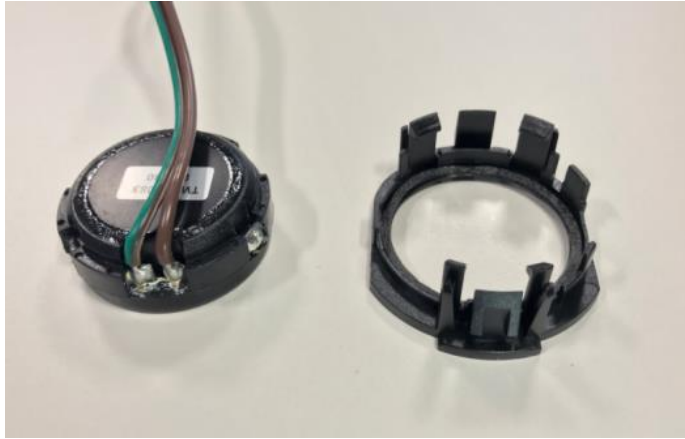

VII - ASSEMBLAGE DES TWEETERS

3. Insérez le tweeter dans l'entretoise



 **Note :** Les pièces doivent être disposées exactement comme sur la photo.

4. Connectez sur la position 2



 **Note :** La position 1 n'est pas utilisée dans cette configuration.

VIII - INSTALLATION DES TWEETERS ARRIERES

1. Connexion du filtre tweeter sur connecteur d'origine



Connecteur d'origine

2. Clipper le tweeter Focal dans l'emplacement d'origine



Remplacé par :



VIII - INSTALLATION DES TWEETERS ARRIERES

3. Connexion du filtre au tweeter lors du remontage de la garniture

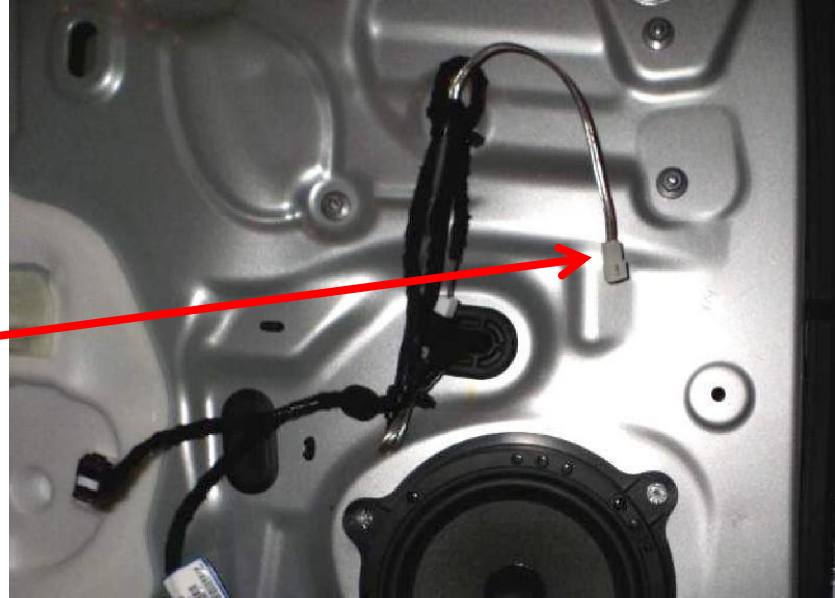

VII - PREPARATION DU CAISSON

1. Eléments nécessaires au montage du caisson

Câble de masse



Câble d'alimentation



Manchon à sertir

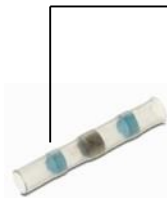

Adaptateur d'alimentation



Câble et télécommande du caisson



Adaptateur



Ibus 2.1



Câble d'extension



Câble de liaison autoradio/caisson



Velcro®



Connecteurs



VII - PREPARATION DU CAISSON

1. Préparation du câblage

a. Coupez

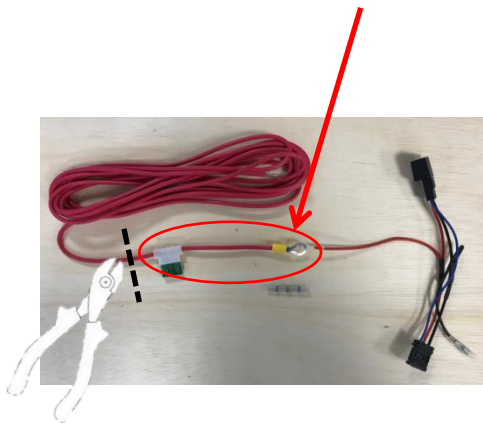

b. Placez le manchon à sertir par-dessus les câbles dénudés.

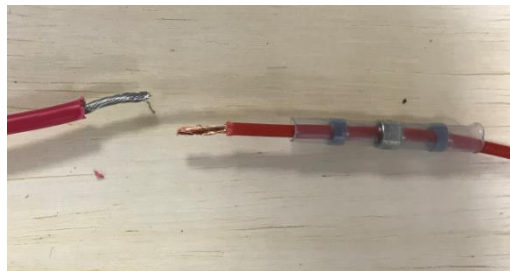

c. Utilisez un pistolet thermique pour chauffer le manchon à sertir.

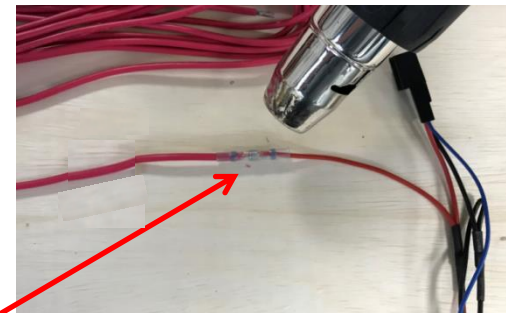

VII - PREPARATION DU CAISSON



d. Connectez l'adaptateur au câble d'extension.

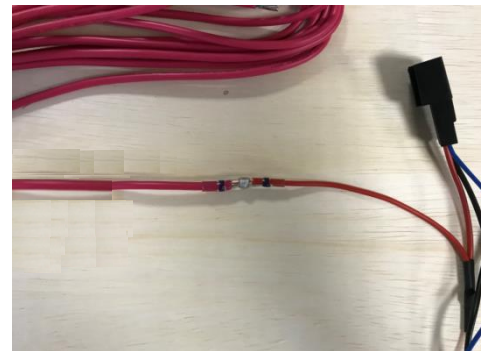

e. Positionnez les câbles sur le caisson sans brancher.



f. Scotch les câbles ensemble tous les 20 cm.

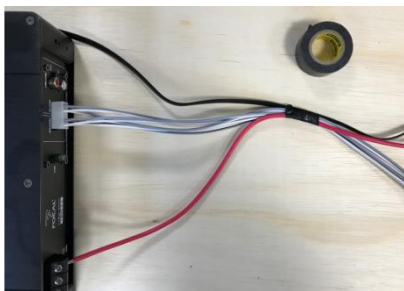

g. Laissez de la marge pour le passage des câbles côté autoradio.

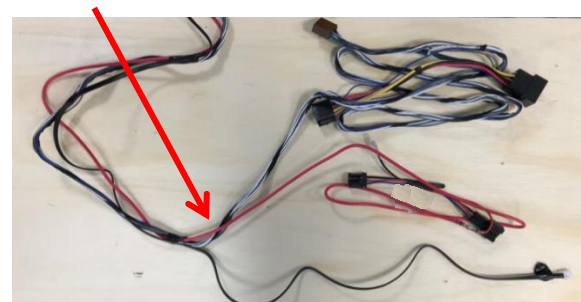

VIII - MONTAGE DU CAISSON

1. dépose du cache supérieur de la console centrale



2. Déconnectez les deux baguettes éclairées puis les retirer



VIII - MONTAGE DU CAISSON

3. dépose des caches plastiques coté conducteur et passager

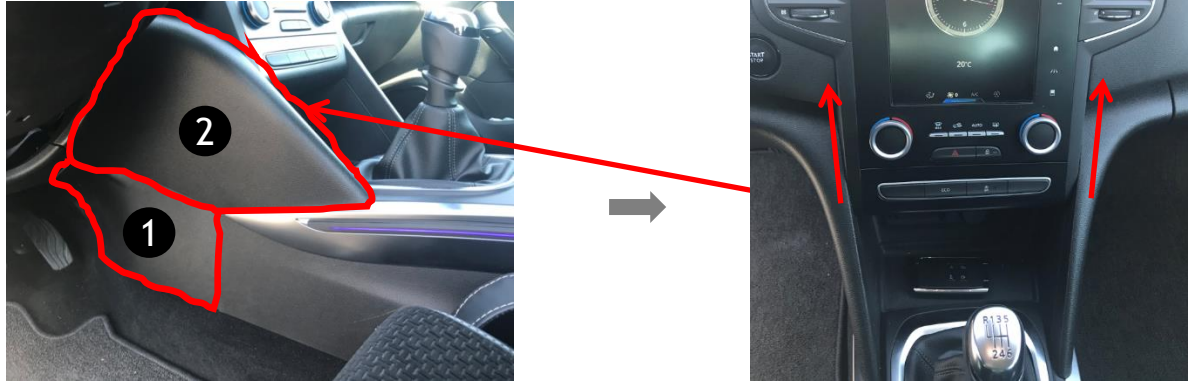

4. Dépose du cache extérieur de l' autoradio

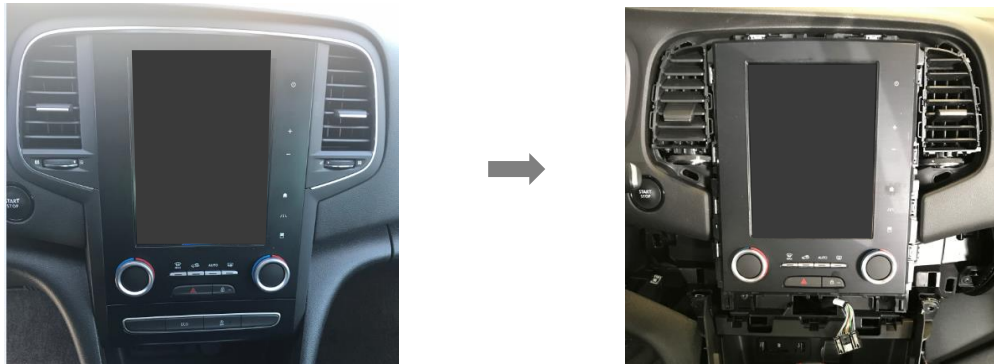

VIII - MONTAGE DU CAISSON

5. Dévisser les vis pour reculer la console centrale

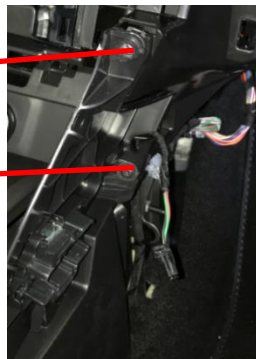

Note : à dévisser de chaque côté.

VIII - MONTAGE DU CAISSON

6. Reculer la console centrale puis retirer le cache plastique

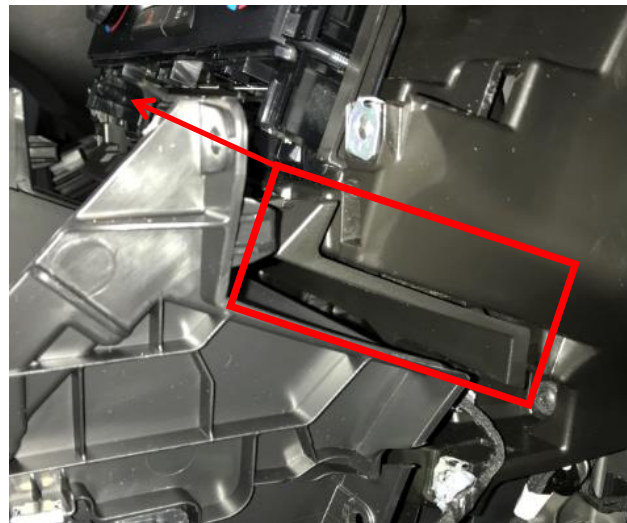

VIII - MONTAGE DU CAISSON

1. Connexion au 12 v allume cigare (avant ou arrière)

1. Dans le cas du montage, connexion à celui de l'arrière

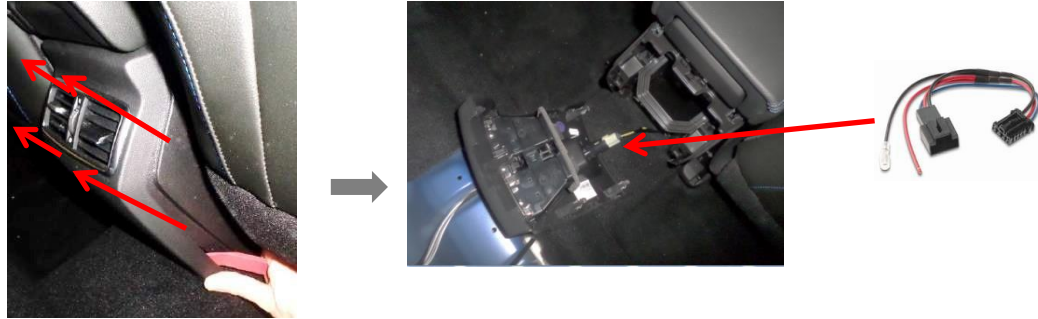

2. Connexion à l'autoradio

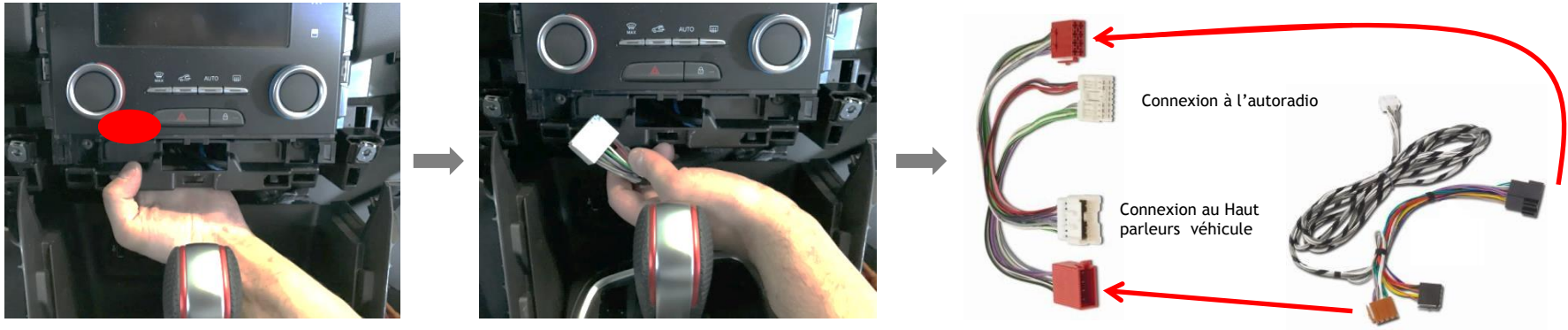

VIII - MONTAGE DU CAISSON

2. Passage de la tresse de l'avant à l'arrière du véhicule

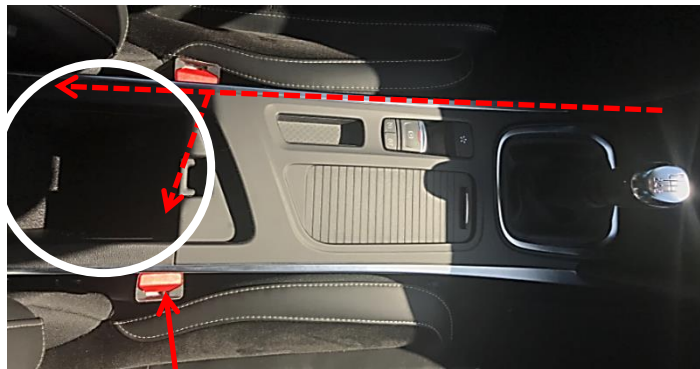

Note : Fixez la télécommande avec du Velcro® (recommandé).

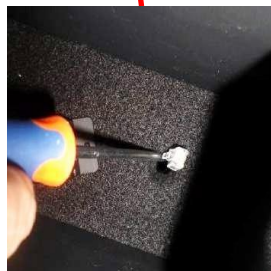

Note : Bien fixer le câble à la sortie du passage dans la moquette de sol.

VIII - MONTAGE DU CAISSON

3. Connexion du câble de masse (noir)

a. Connexion du câble de masse

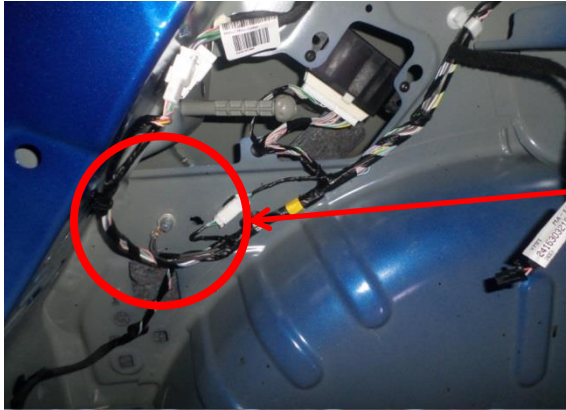

VIII - MONTAGE DU CAISSON

4. Positionnez le caisson

a. A positionner au dos de la banquette 1/3 (Il est conseillé de visser le caisson à l'aide des vis fournis et des patins en caoutchouc)



Note : Fixez le caisson avec le Velcro® fournis.



VIII - MONTAGE DU CAISSON

b. Câblez (arrière)



c. Câblez (avant - télécommande)



VIII - MONTAGE DU CAISSON

d. Réglages du caisson.

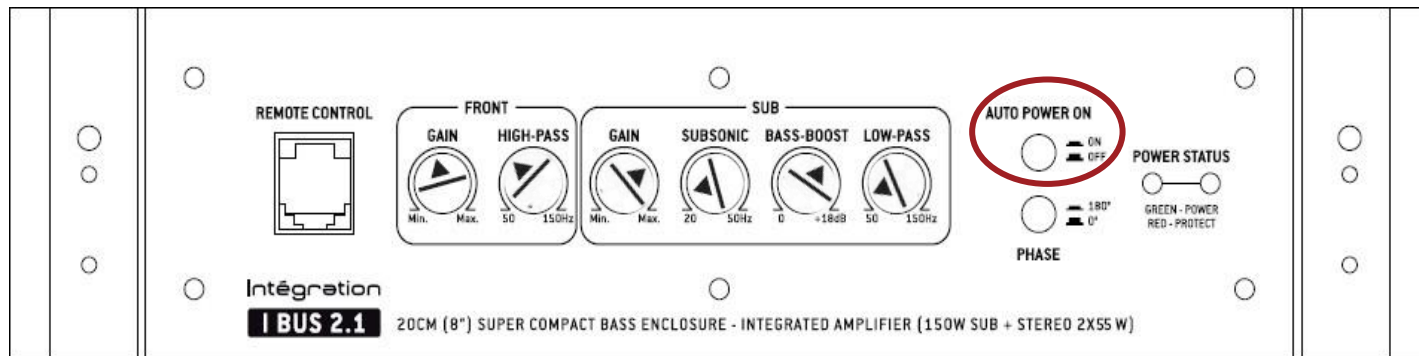

Auto Power = ON
Phase = 0°

IX - ACCESSOIRES

a. Autocollants : Ajoutez les autocollants fournis dans votre kit pour customiser les grilles des tweeters.



a. Avant



b. Arrière



FOCAL[®] *INSIDE*

www.focal-inside.com